

*FASTCAM SA8*

 Hardware Manual

*Revision 1.00E*

- The copyright of this manual is held by Photron LIMITED.
- Product specifications and manual contents can change without advanced notification.
- This manual was created taking every possible measure to ensure the accuracy of its contents. However, if you find a section which is unclear, a mistake, or an omission, please contact Photron LIMITED using the contact information provided at the end of the manual.
- Photron LIMITED bears no responsibility for the results of using the product or from following the instructions in this manual.

## Introduction





Thank you for your purchase of Photron's high-speed camera system, the "FASTCAM SA8" (referred to below as the system). This manual contains the operating instructions and warnings necessary for using the system.

Before using the system, please read the entire manual. If any part of this manual is unclear, contact Photron using the contact information printed at the back of the manual.

After you finish reading the manual, store it in a safe place along with the warranty card and refer back to it when necessary.

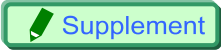
## Manual Notation

The following icons and symbols are used in the explanations in this manual.

Icon/Symbol	Description
 Supplement	This symbol indicates supplementary items to be aware of when using the software.
 Reference	This symbol indicates the location of a reference.
 Important	This symbol indicates content that should always be read.
 Caution	This symbol indicates instructions that should always be followed when using the software, or things to be careful of when using the system.
 MEMO	This symbol indicates a space for you to make notes.
" "	This symbol is used to indicate the names of items on a screen, references, dialog names, and connectors.



# Using the Manual

---

This section explains the layout of the manual.

◆ Introduction

The introduction explains the manual and safety precautions.

◆ Chapter. 1 Overview

This chapter gives an overview of the system and an explanation of its features.

◆ Chapter. 2 Setup

This chapter gives an overview of the components that make up the system. It also explains basic keypad operation and a list of items that should be checked before using the system.

◆ Chapter. 3 Recording

This chapter explains operations related to recording.

◆ Chapter. 4 Connecting a PC

This chapter explains the procedure for connecting the system to a PC. Refer to the “Photron FASTCAM Viewer User’s Manual” for additional details on using a PC to control the system.

◆ Chapter. 5 Product Specifications

This chapter explains the system’s specifications.

◆ Chapter. 6 Warranty

This chapter explains about the warranty.

◆ Chapter. 7 Contacting Photron

This chapter lists the contact information to use when contacting Photron if the system malfunctions or if a portion of the manual is unclear.

## Using the System Safely and Correctly

In order to prevent injury to yourself and others, and to prevent damage to property, carefully observe the following safety precautions.

Photron has given its full attention to the safety of this system. However, the extent of damage and injury potentially caused by ignoring the content of the safety precautions and using the system incorrectly is explained next. Please pay careful attention to the content of the safety precautions when using the system.



### Warning

This symbol indicates actions that carry the risk that a person could receive a serious injury.



### Caution

This symbol indicates actions that carry the risk that a person could receive a moderate injury, or that damage to physical property might occur.

- ◆ The safety precautions to be observed are explained with the following symbols.



This symbol indicates actions that require caution.



This symbol indicates actions that are prohibited and must be avoided.



This symbol indicates actions that must always be performed.



## Warning



- Do not perform actions that will damage the AC cable or plug.  
(Do not damage the cable, modify it, use it near a heater, excessively bend, twist or pull on it, place heavy objects on it, or bundle it.)  
Using the cable when damaged can cause fire, electric shock, or a short circuit.



- Do not use the system in a manner which will exceed the rating of the power outlet or wiring equipment used.  
Exceeding the power rating might cause a fire from excessive heat.



- Do not insert metallic objects inside, or pour liquids such as water on, the system.  
Doing so can cause fire, electric shock, or malfunction from short circuit or heat.



- Do not disassemble or modify the system.  
There are high voltages inside the system that can cause electric shock.



- Do not plug in or unplug the power cord with wet hands.  
Doing so can cause electric shock.



- This chapter lists the contact information to use when contacting Photron if the system malfunctions or if a portion of the manual is unclear.  
Not fully plugging in the power cable can cause fire from electric shock or heat.



- When something is wrong with the system, unplug the power cable immediately.
  - When a foreign substance or liquid, such as metal or water, gets inside.
  - When the outer case is broken or damaged, such as from a fall.
  - When the system produces smoke, a strange smell, or strange sound.Using the system in these conditions might cause a fire or electric shock.



## Caution



- Always unplug the system when cleaning it or when it is unused for a long period of time. Leaving or storing the system connected to the power source might cause fire from insulation deterioration or electrical discharge.



- Please consult us in advance when you perform an event by which laser light or direct rays fall on the image sensor surface.



- Do not set the system in a location where the temperature gets unusually hot. The trunk and inside of a car can get especially hot in summer. Doing so can cause the outer case and internal components to deteriorate or cause a fire.



- Do not place the system in a location prone to oily smoke or steam, or in a location with a lot of humidity or dust. Oil, moisture, and dust conduct electricity, which can cause a fire or electric shock.



- Ambient temperature 0-40° C, humidity 85% RH or lower, maximum altitude 2000m or lower. In addition, if exceeding these limits, use in a condensation-free environment. Doing so can cause malfunction.



- Do not store the equipment in a location where the temperature goes below -20°C or higher than 60°C. Also, prevent condensation from forming during shipment



- This device is for indoor use, do not use it outdoors. Do not use in a location that has dust. Doing so can cause malfunction.



- When shipping, remove the connecting cable and use the original packaging or a dedicated carrying case. Do not ship the equipment in an environment where the temperature goes below -20°C or higher than 60°C. Also, prevent condensation from forming during shipment



## Cleaning of the Image Sensor Surface

Electrostatic Discharge (ESD) events may cause immediate and unrecoverable damage to the image sensor. Please read the following instructions and take **EXTREME CARE** when cleaning the image sensor surface.



- ALWAYS take appropriate anti-static precautions when cleaning or working near the Image sensor.
- DO NOT use any form of cleaning equipment using electrostatic or 'charged fiber' technology.



- Please discharge any electrostatic build up in your body by touching a grounded metallic Surface before working near the camera sensor.
- Very gently, use only clean and dry air to remove dust from surface of the image sensor.
- To remove stubborn contamination use the highest grade (e.g. VLSI grade) pure Isopropyl alcohol (IPA) with optical wipes of 'clean room' grade.
- Extreme care must be taken! Gently wipe across the sensor in a single action.  
(DO NOT rub to avoid abrasive damage to delicate optical coatings on the glass surface.)

# Table of Contents

<b>Chapter. 1</b>	<b>Overview</b>	<b>1</b>
1.1.	Product Overview and Features .....	2
<b>Chapter. 2</b>	<b>Setup</b>	<b>3</b>
2.1.	System Components and Accessories .....	4
2.1.1.	Components .....	4
2.1.2.	Accessories/Options .....	4
2.1.3.	Type .....	5
2.2.	Part Names .....	6
2.2.1.	Camera Body .....	6
2.2.2.	Camera Body Part Names .....	7
2.2.3.	Status Display LEDs on the Rear of the Camera Body .....	8
2.2.4.	Interchangeable Lens Mounts.....	10
2.2.5.	Remote Controller (Optional).....	11
2.2.6.	RS-422 Serial Control .....	12
2.2.7.	I/O Port Connector .....	13
2.2.8.	Power Supply Connector .....	15
2.3.	Device Connections .....	16
2.3.1.	Connecting a Video Monitor.....	16
2.3.2.	Connecting the Power Supply.....	17
2.3.3.	Connecting the Keypad (Optional).....	18
2.3.4.	Connecting a PC.....	19
2.3.5.	Factory Default Setting .....	19
2.3.6.	Memory Backup Battery (Option) .....	20
<b>Chapter. 3</b>	<b>Recording</b>	<b>21</b>
3.1.	Selecting the Frame Rate .....	22
3.2.	Selecting the Resolution .....	22
3.3.	Selecting the Shutter Speed .....	23
3.4.	Selecting the Trigger Mode.....	23
3.4.1.	START Mode.....	23
3.4.2.	CENTER Mode .....	24
3.4.3.	END Mode.....	24
3.4.4.	MANUAL Mode .....	24
3.5.	LOW LIGHT Mode .....	25
3.6.	White Balance Adjustment (Color Types Only).....	25
3.6.1.	Using Preset White Balance (Color Types Only).....	25
3.6.2.	Using User White Balance (Color Types Only).....	25
3.7.	Color Enhancement Function (Color Types Only) .....	26
3.8.	LUT (Look-Up Table) Operations.....	26
3.8.1.	Using Preset LUT Patterns .....	26
3.8.2.	Using a Custom LUT.....	29

3.9. Edge Enhancement Function .....	29
3.10. Input / Output Signal Types.....	30
3.10.1. TRIG TTL IN Connector .....	30
3.10.2. TRIG TTL OUT Connector .....	30
3.10.3. TRIG SW IN Connector .....	30
3.10.4. SYNC IN Connector .....	30
3.10.5. GENERAL IN Connector.....	31
3.10.6. GENERAL OUT (1, 2) Connector .....	31
3.11. Using External Triggers.....	32
3.11.1. Inputting an External Trigger Signal.....	32
3.11.2. Outputting External Trigger Signals .....	34
3.12. Using External Synchronization Signals.....	35
3.12.1. Inputting an External Synchronization Signal .....	35
3.12.2. Outputting an External Synchronization Signal .....	35
3.12.3. Synchronization with a variable frequency .....	35
3.12.4. Synchronizing Multiple FASTCAM SA8 Systems(Multiple Unit Synchronized Recording).....	36
3.12.5. Synchronizing the System with Other Cameras (Mixed Device Synchronized Recording).....	38
3.13. GENERAL Signal Settings.....	39
3.13.1. GENERAL IN Signal Settings .....	39
3.13.2. GENERAL OUT Signal Settings .....	40
3.14. Signal Delay .....	41
3.15. Using USER SW (Programmable Switch) .....	42
3.16. IRIG Time Code (External Time Synchronization).....	43
3.17. 8bit Recording Mode.....	44

## **Chapter. 4 Connecting a PC 45**

4.1. Connecting the Gigabit Ethernet Interface to a PC .....	46
4.1.1. Connecting the System and a PC.....	47
4.1.2. Setting the IP Address .....	47
4.1.3. Using DHCP (Dynamic Host Configuration Protocol).....	47
4.1.4. Connecting Multiple Systems and a PC .....	48
4.1.5. Gigabit Ethernet Interface Initialization .....	48
4.1.6. Camera IP Address Initialization .....	48

## **Chapter. 5 Product Specifications 49**

5.1. Specifications.....	50
5.1.1. Product Specifications .....	50
5.1.2. General Specifications .....	51
5.1.3. AC / DC Adaptor .....	51
5.1.4. Options.....	52
5.1.5. Frame Rate and Resolution .....	54
5.1.6. Recordable Image Count/Resolution(12bit).....	58
5.1.7. Recordable Image Count/Resolution(8bit).....	59
5.1.8. Shutter Speed List .....	60

5.2. Dimensions .....	61
5.2.1. Camera Body .....	61
5.2.2. AC / DC Adaptor .....	62
5.2.3. Memory Backup Buttery.....	62
5.2.4. Remote Keypad (Option) .....	63

<b>Chapter. 6 Warranty</b>	<b>65</b>
----------------------------	-----------

6.1. About the Warranty .....	66
-------------------------------	----

<b>Chapter. 7 Contacting Photron</b>	<b>67</b>
--------------------------------------	-----------

7.1. Contact Information.....	68
-------------------------------	----



# Chapter. 1 **Overview**

---

## **1.1. Product Overview and Features**

## 1.1. Product Overview and Features

---

The FASTCAM SA8 is a powerful engineering tool for use in research and development, design, production, and quality control, and in numerous fields such as science, medicine, biology, aviation and space. -The system features superior basic performance with megapixel resolution, an ultra-sensitive image sensor capable of clear recording in low-light, and an high speed frame rate of a maximum with full frame of 3,500fps (15K type: 2,000fps) It also allows operation from the PC software via a gigabit Ethernet connection to more easily implement analysis of dynamic bodies that had been difficult to analyze until now.

Use the state-of-the-art technology in the FASTCAM SA8 to slow down and observe high-speed dynamic bodies and also as an input component for a dynamic image measurement system.



# Chapter. 2 **Setup**

---

**2.1. System Components and Accessories**

**2.2. Part Names**

**2.3. Device Connections**

## **2.1. System Components and Accessories**

---

### **2.1.1. Components**

The system's standard components are listed below. Remove the components from the packaging and check them.

1.	Camera Body	One
2.	AC / DC Adaptor , AC Cable	One
3.	G type F Mount Adapter (body integrated)	One
4.	C Mount Adapter (cap integrated)	One
5.	Hexagonal Wrench for Changing Lens Mounts (1.5 mm, 2 mm, 3 mm, 4 mm)	One each
6.	I/O Cable	One
7.	FASTCAM Series Setup Disk (Driver / Application DVD)	One
8.	FASTCAM SA8 Hardware Manual (This Manual)	One
9.	Photron FASTCAM Viewer User's Manual	One
10.	Making a Gigabit Ethernet Connection (Simple Procedure Manual)	One
11.	Gigabit Ethernet Interface Cable (LAN Cable)	One

### **2.1.2. Accessories/Options**

The following options are available for the system.

1. Remote Keypad
2. 4 Output Trigger Box
3. Spare Power Supply Connector (For Creating a Custom Cable)
4. Dust-Proof Cover for the LAN Connector
5. Carrying Case
6. Memory Backup Battery

---

### **2.1.3. Type**

The system is split into types according to frame rate, color/monochrome, and amount of memory. There are a total of 8 types according to the combination of options.

The types are listed below.

Max. Frame Rate	Full Frame Max Frame Rate	Sensor Type	Memory	Type Name
30,000fps	3,500fps	Color	4GB	FASTCAM SA8 type 30K-C1
			8GB	FASTCAM SA8 type 30K-C2
		Monochrome	4GB	FASTCAM SA8 type 30K-M1
			8GB	FASTCAM SA8 type 30K-M2
15,000fps	2,000fps	Color	4GB	FASTCAM SA8 type 15K-C1
			8GB	FASTCAM SA8 type 15K-C2
		Monochrome	4GB	FASTCAM SA8 type 15K-M1
			8GB	FASTCAM SA8 type 15K-M2

## 2.2. Part Names

---

The system is composed of components including the camera body, AC / DC Adaptor, and the "Photron FASTCAM Viewer" control software (referred to below as PFV).



For each of the system components.

- Do not expose to shock outside of specifications.
- Do not use in an area with flammable gas or dust present.
- Do not place in an unstable location such as on an unstable platform or an incline.
- Do not disassemble or modify.
- Do not expose to liquids such as water.
- Do not use in a manner where excessive force is applied.

### 2.2.1. Camera Body

The camera body contains IC memory for saving images and has been designed with the capability to save high-speed images as uncompressed digital data. The camera body has a Gigabit Ethernet interface to connect a PC to fully control the camera or download data, and interfaces for various I/O (input/output) connectors for external synchronization/trigger signals.



**Appearance**



**Rear**

## 2.2.2. Camera Body Part Names

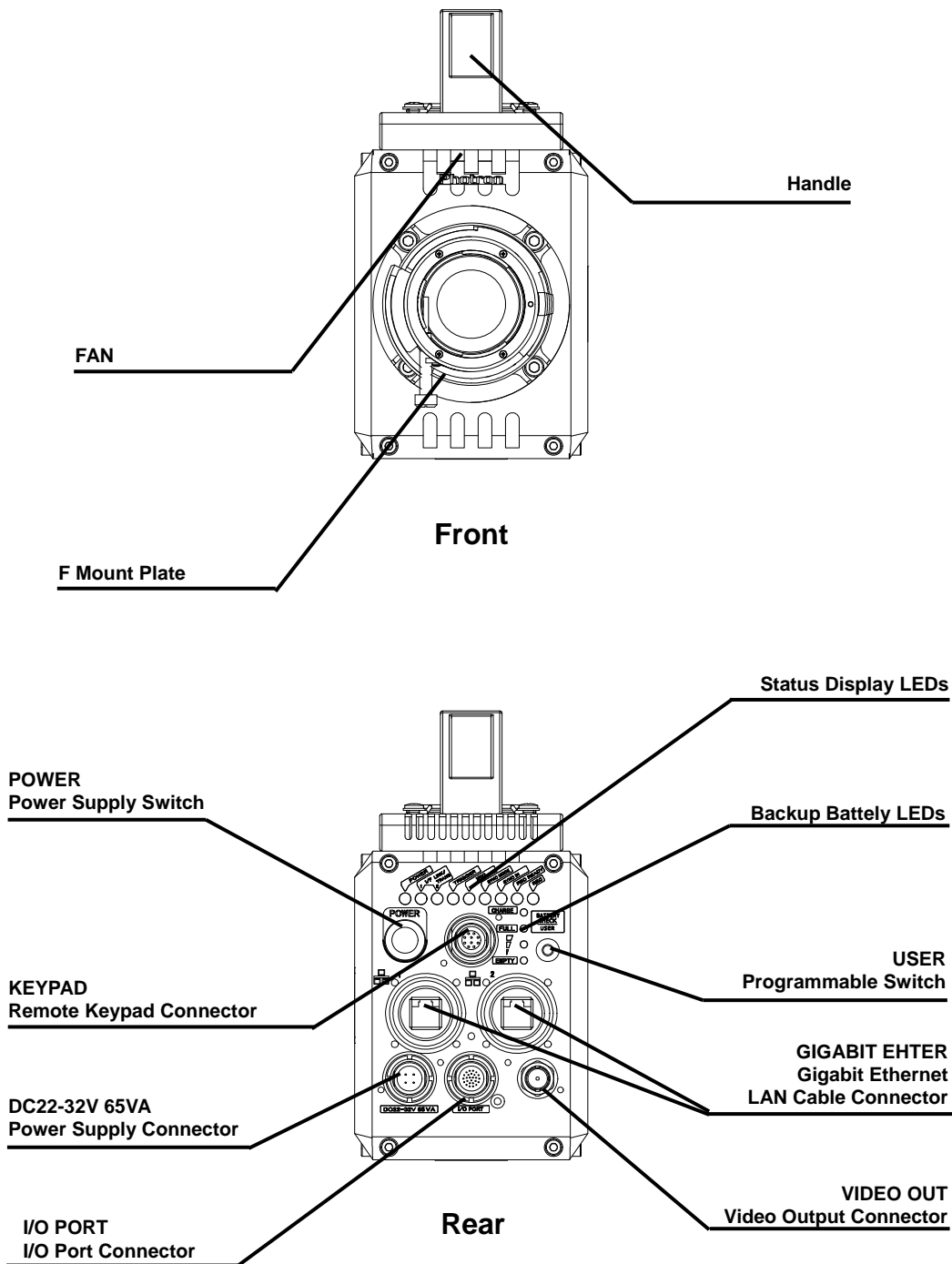

### 2.2.3. Status Display LEDs on the Rear of the Camera Body

There are a number of LEDs on the rear of the system's camera body. These LEDs indicate the status of the system. The meaning of each LED is explained here.

#### ◆ Status Display LEDs



- **POWER (Green)**  
LED ON: Power On  
LED OFF: Power Off
  
- **I/F LINK/TRANS (Red)**  
LED ON: The Gigabit Ethernet interface is connected  
LED FLASHING: Data is transferring  
LED OFF: The Gigabit Ethernet interface is not connected
  
- **TRIGGER (Yellow)**  
LED ON: A trigger signal has been input (illuminates for 0.1 s when the trigger signal is input)  
LED OFF: A trigger signal has not been input
  
- **IRIG (Green)**  
LED ON: A IRIG signal has been input  
LED OFF: A IRIG signal has not been input
  
- **SYNC MODE (Red)**  
LED ON: In external synchronization mode  
LED OFF: In internal synchronization mode
  
- **SYNC IN (Yellow)**  
LED ON: A synchronization signal is being input  
LED OFF: A synchronization signal is not being input
  
- **REC READY (Yellow)**  
LED ON: Ready to record  
LED FLASHING: ENDLESS recording ("REC" LED also simultaneously flashes)  
LED OFF: Not ready to record
  
- **REC (Red)**  
LED FLASHING: Recording  
LED OFF: Not ready to record

◆ Statement of LED blinking status.

- Working under LOW LIGHT mode.  
LEDs except POWER (Green) and IF LINK/TRANS (Red) blink synchronously in a certain interval.
- Initialization of Gigabit Ethernet Interface and Initialization of IP address.  
LEDs except POWER (Green) and IF LINK/TRANS (Red) blink from left to right for 3 circles and right to left for 3 circles alternately.

 Reference

- For Initialize Gigabit Ethernet Interface, refer to "4.1.5. Gigabit Ethernet Interface Initialization", page48.

◆ Battery LED (Option)

- CHARGE (Red)  
LED ON : Battery in charging.  
LED OFF : Not in charging.
- FULL (Green) → (Yellow) → EMPTY (Red)  
Indicator of residual battery capacity.  
Green: residual battery capacity 100%~90%  
Yellow: residual battery capacity 89%~21%  
Red: residual battery capacity 20%~1%

Moreover, the status of battery is indicated by blinking of LED.  
LED ON : Working under an External Power Supply state.  
LED FLASHING : Battery Powered Memory Protect state.



## **2.2.4. Interchangeable Lens Mounts**

The lens mount on the system can be changed according to the recording application. There are three types of interchangeable lens mounts, "Nikon G type F Mount", "C Mount", and Lens mount with filter changer.

◆ How to change lens mounts (Nikon G type F Mount → C Mount)

1. Remove the four M5 hexagonal socket bolts with the hexagonal wrench.
2. Remove the Nikon G type F mount portion as a whole unit.
3. Attach the C mount unit with the hexagonal socket bolts 90 degrees diagonally.
4. After attaching the unit, always check to make sure it is not loose and rattles.

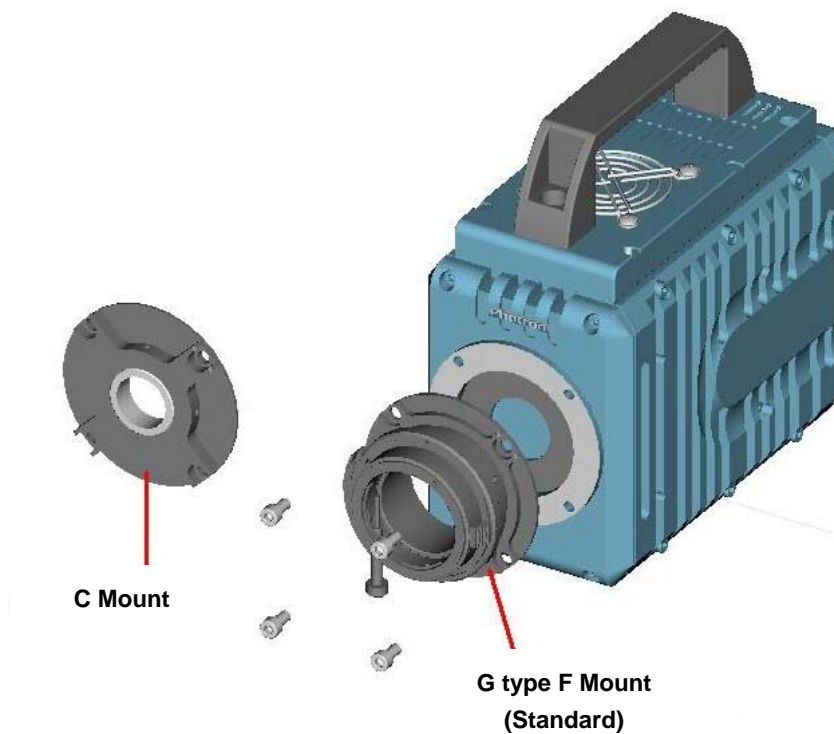

## 2.2.5. Remote Controller (Optional)

The system can be operated while checking the monitor by connecting the optional remote controller to the "KEYPAD" connector on the rear of the camera body. The remote controller is also hot-pluggable; it can be plugged into and unplugged from the camera while the power is on.

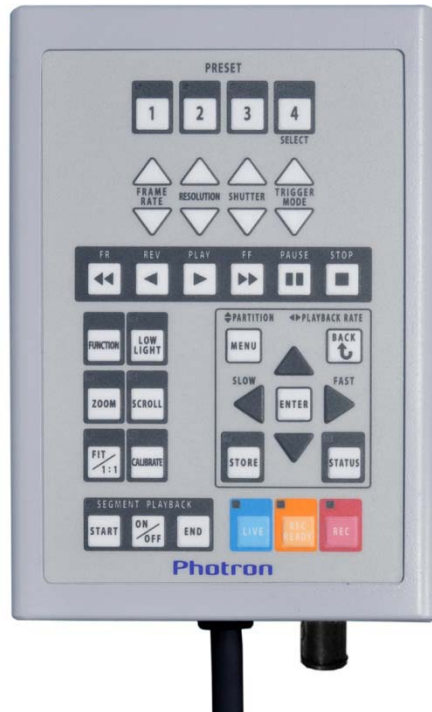

Camera Body Connector	Signal	Camera Body Connector Model Name (Manufacturer)	Keypad Connector Model Name (Manufacturer)
KEYPAD	Keypad signal	G52L0C-P10QJ00-0000 (ODU)	S22L0C-P10MJG0-820S (ODU)

### Supplement

- The remote controller is optional. It is not included in the standard configuration.

### Reference

- For how to operate of the Remote Controller, refer to "Remote Controller User's Manual".

## 2.2.6. RS-422 Serial Control

The system supports serial control via an RS-422 connection through the "KEYPAD" connector. By setting the [STATUS OUT] menu to ON, the system status can be output via the serial connection.

For details, check the command list.

Serial control commands are available as separate list of commands. Please contact Photron or the dealer where the system was purchased regarding the command list.

A cable is also not offered as an accessory. When using RS-422 control, construct a cable using the pin diagram below for reference.

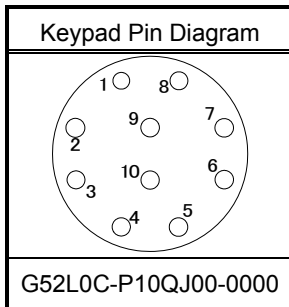

Connector Name	Signal Name	Pin No.	Camera Body Connector Model Name (Manufacturer)	Cable Connector Model Name (Manufacturer)	Input Connector
KEYPAD	VBS	1	G52L0C-P10QJ00-0000 (ODU)	S22L0C-P10MJG0-820S (ODU)	Not Specified
	GND	2			
	RXD+	3			
	RXD-	4			
	TXD+	5			
	TXD-	6			
	GND	7			
	TRIGGER SW	8			
	GND	9			
	+12V OUT	10			



When using the connector pins directly, refer to the chart above and ensure the wiring is correct. Incorrect wiring can cause malfunction.



The voltage on pin 10 (+12V OUT) is used to power the remote controller, do not use it for other purposes.

### Reference

- For inquiries related to our product, refer to "7.1. Contact Information", page 68.

## 2.2.7. I/O Port Connector

By inputting an external trigger or synchronization signal and by outputting exposure timing or synchronization signal, these signals can be used as a part of the system. The input/output signal connectors on the system have been bundled into a single connector, the "I/O port" connector, and it is possible to connect to and access each type of signal by using the specialized multi-connector.



Do not input a signal other than the specified signal to the various connectors.

Use extreme caution as there is a risk of damage to both devices, the input device and the output device.

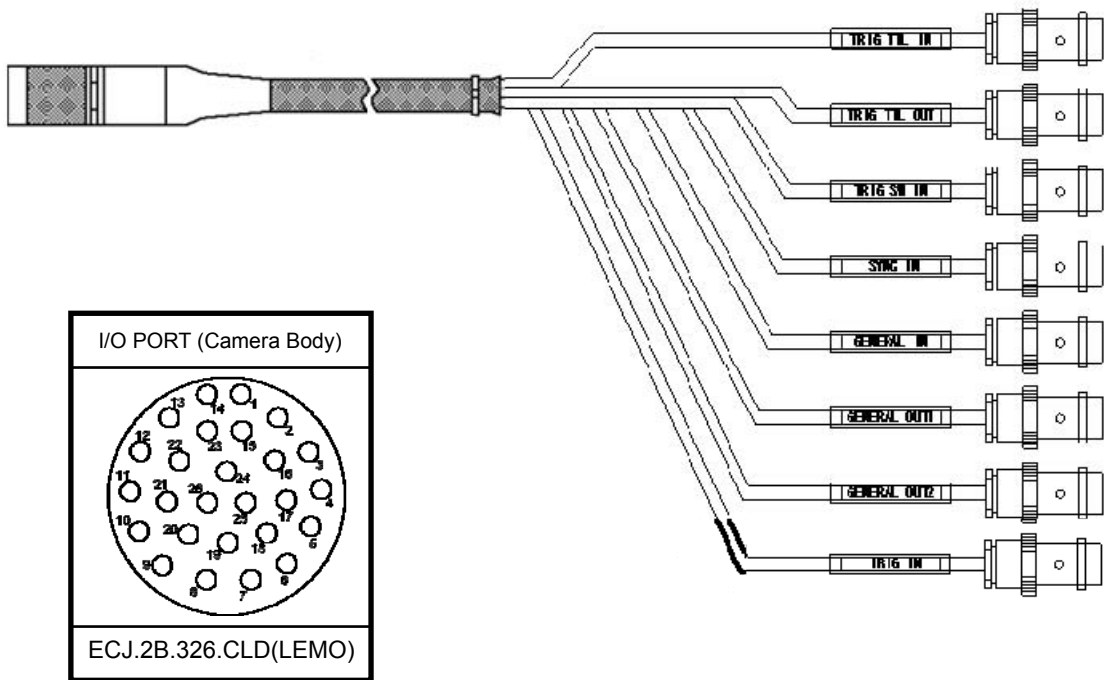

### Reference

- For the signal which can be inputted, refer to "3.10. Input / Output Signal Types", page 30.

Connector Name	Signal Name	Pin No.	Camera body Connector type No. (Manufacturer)	Cable connector type No. (Manufacturer)	Input connector
I/O PORT	GENERAL OUT2	1	ECJ.2B.326.CLD (LEMO)	FGJ.2B.326.CLLD92Z (LEMO)	BNC
	RESERVE	2			-
	GND	3			BNC
	RESERVE	4			-
	RESERVE	5			-
	RESERVE	6			-
	RESERVE	7			-
	RESERVE	8			-
	IRIG GND	9			BNC
	IRIG	10			BNC
	SYNC IN	11			BNC
	TRIGGER TTL IN	12			BNC
	TRIGGER TTL OUT	13			BNC
	GENERAL OUT1	14			BNC
	GND	15			BNC
	GND	16			BNC
	RESERVE	17			-
	RESERVE	18			-
	GND	19			BNC
	RESERVE	20			-
	GENERAL IN	21			-
	TRIGGER SW	22			BNC
	+22 - +32V (Input)	23			-
	+22 - +32V (Input)	24			-
	+22 - +32V (Input)	25			-
	GND	26			BNC

 **Supplement**

- Pin 3, 15, 16, 19, 26's GND signal is the common ground for BNC.

## 2.2.8. Power Supply Connector

This connector is the connector to input the DC power supply. Connect the supplied AC / DC Adaptor. A cable connector is available as an option. When using other power supplies, construct a cable using the pin diagram below for reference.

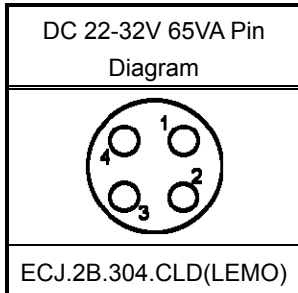

Connector Name	Signal Name	Pin No.	Camera body connector type name (Manufacturer)	Cable connector type name (Manufacturer)
DC 22-32V 65VA	N.C.	A	ECJ.2B.304.CLD (LEMO)	FGJ.2B.326.CLLD92Z (LEMO)
	SIGNAL GND	B		
	POWER GND	C		
	+22V~+32V IN	D		



### Warning

When using the connector pins directly, refer to the chart above and ensure the wiring is correct.

If the wiring is incorrect, not only is there the danger of the system malfunctioning, but also of fire and electric shock.



### Warning

Do not use a power supply which does not meet the system's specifications, or a power supply you cannot guarantee the safety of.

By using a power supply outside of the system specifications, not only is there the danger of the system malfunctioning, but also of fire and electric shock.

## 2.3. Device Connections

### 2.3.1. Connecting a Video Monitor

A video monitor connected to the camera controller can be used to check the live image (Camera Pass - through image). Connect the video input connector according to the video signal type of the monitor to display to the "VIDEO OUT" connector on the rear of the camera body with a BNC cable.

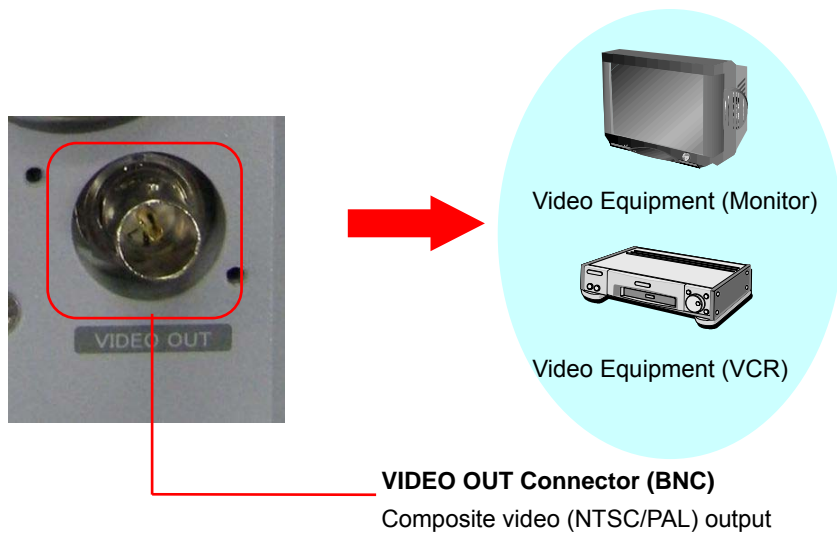

## 2.3.2. Connecting the Power Supply

Connect the supplied AC / DC Adaptor to the power supply.

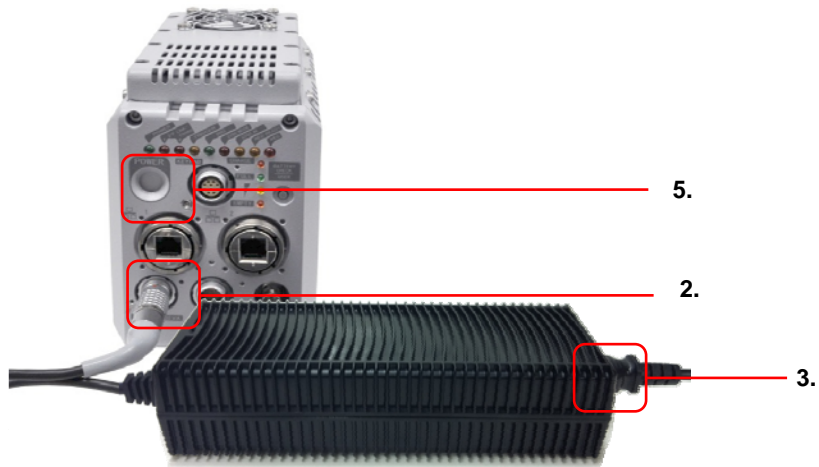

**AC / DC Adaptor Connection**

1. Confirm the Power SW is turned off.
2. Connect the AC / DC Adaptor to the “DC22-32V 65VA” connector on the back of the camera body.
3. Connect the AC cable to the AC / DC Adaptor.
4. Connect the AC cable to the power outlet.
5. Turn on the Power SW one the system

### Reference

- For the specification of the power supply which can be used, refer to “5.1.2. General Specifications”, page 51.

### 2.3.3. Connecting the Keypad (Optional)

---

If you have the optional Keypad, connect it by plugging the Keypad connector into the connector labeled "KEYPAD" on the rear of the camera body.



#### Supplement

- The Keypad is hot-pluggable. It can be plugged in and removed while the system's power is on.

#### Reference

- For how to operate of the Keypad, refer to "Remote Keypad User's Manual".

---

### **2.3.4. Connecting a PC**

The system can have the operation of its functions performed from a PC using the Gigabit Ethernet interface.

This section explains the required setup when connecting the system to a PC.

To connect a PC to the system, connect the system to a commercially available 1000BASE-T-compatible interface board with a LAN cable. For the LAN cable, prepare a UTP or STP CAT5E (enhanced category 5) or higher category LAN cable. (UTP: Unshielded Twisted Pair, STP: Shielded Twisted Pair)

The maximum cable length between the PC and the system is 100 m (compliant to the 1000BASE-T specification). One PC can connect to a maximum of 64 Photron Gigabit Ethernet interface equipped cameras using a hub. When connecting multiple devices, connect through a switching hub that can connect at 1000BASE-T. The maximum length of the cable that connects the system (or PC) to the switching hub is also 100 m.

#### Reference

- For operating instructions of Photron FASTCAM Viewer software, refer to "Photron FASTCAM Viewer User's Manual".

### **2.3.5. Factory Default Setting**

This system can be restored to the factory settings state.

#### Reference

- For operating instructions of Photron FASTCAM Viewer software, refer to "Photron FASTCAM Viewer User's Manual".

### 2.3.6. Memory Backup Battery (Option)

As an optional accessory, a battery set for conserving video information in the camera memory is available. In case of an outer power-fail, it can maintain the content of the memory for about 30 minutes in maximum. While powering the system using an outer power supply, the battery set will be charged automatically.

Moreover, by pressing the "BATTERY CHECK" button, LEDs can illuminate and the charging status of the battery can be confirmed even when the outer power supply is cut.



#### Important

- Before recording, check the battery gauge LED, and test and confirm the behavior of camera when the external power supply becomes disconnected with the POWER SW is kept on.

Replace the battery, in case of the camera stops without supplying power from the battery, or CHARGE LED is turned off before the battery gauge LED indicates FULL. The cause is that the battery has a trouble or the lifetime has been out.

- The charging stops automatically by a safety circuit when environment temperature becomes out of a specification. And the charging restarts when the temperature comes back in the specification.
- The longevity of battery is about 1 year. However, acknowledge that it could change according the working circumstance.

For exchange of battery, refer to "7.1. Contact Information", Page 80.

# Chapter. 3 Recording

---

- 3.1. Selecting the Frame Rate**
- 3.2. Selecting the Resolution**
- 3.3. Selecting the Shutter Speed**
- 3.4. Selecting the Trigger Mode**
- 3.5. LOW LIGHT Mode**
- 3.6. White Balance Adjustment (Color Types Only)**
- 3.7. Color Enhancement Function (Color Types Only)**
- 3.8. LUT (Look-Up Table) Operations**
- 3.9. Edge Enhancement Function**
- 3.10. Input / Output Signal Types**
- 3.11. Using External Triggers**
- 3.12. Using External Synchronization Signals**
- 3.13. GENERAL Signal Settings**
- 3.14. Signal Delay**
- 3.15. Using USER SW (Programmable Switch)**
- 3.16. IRIG Time Code (External Time Synchronization)**
- 3.17. 8bit Recording Mode**

## 3.1. Selecting the Frame Rate

---

With the system, you can record images from 60 to 3,500 fps (or 2,000 fps at 15Ktype) using the full 1,280x1,024 pixel resolution of the image sensor. For frame rates faster than 2,000 fps, high-speed photography is achieved by limiting the read area of the image sensor.

### Reference

- For frame rates faster than 3,500 fps, the resolution is automatically set to the maximum available at that frame rate. For more details, refer to “5.1.5. Frame Rate and Resolution”, page 54.

## 3.2. Selecting the Resolution

---

The maximum resolution of the image sensor is 1,280 x 1,024: total 1,310,720 pixels. You can also record at even faster frame rates or reduce the amount of image data to make even longer recordings by limiting the resolution according to the application.

### Reference

- For more information of relation between Frame Rate and Resolution, refer to “5.1.5. Frame Rate and Resolution”, page 54.

### 3.3. Selecting the Shutter Speed

The shutter speed is independent of the frame rate, and you can control the exposure time in one frame using the electric shutter. By making an exposure that is of a shorter period than the frame rate, high-speed objects can be photographed blur-free.

The shutter speed can be set from 1/frame s to a maximum of 1/100,000 s (approximately 10 $\mu$ s).

#### Reference

- For more information of Shutter Speed, refer to “5.1.8. Shutter Speed List”, page 60.

### 3.4. Selecting the Trigger Mode

In order to reliably capture high-speed phenomena, many kinds of trigger modes have been made available. These trigger modes are explained next.

There are four types of trigger modes which are listed below.

- START
- CENTER
- END
- MANUAL

#### 3.4.1. START Mode

START mode is a trigger mode where recording starts the instant the trigger is input, the scene is recorded until the memory is full, and then recording ends. This mode is suitable for taking images of high-speed phenomena when what will happen, and when it happens, is known in advance.

For example, in a situation with a maximum useable memory of two seconds of recording, two seconds of high-speed video is saved immediately after the trigger is input.



### 3.4.2. CENTER Mode

CENTER mode is a trigger mode where an equal amount of content recorded before and after the trigger is input is saved to memory. This mode is suitable for viewing before and after an important instant. For example, in a situation with a maximum useable memory for two seconds of recording, one second before and one second after the trigger was input is recorded for a total of two seconds of high-speed video.

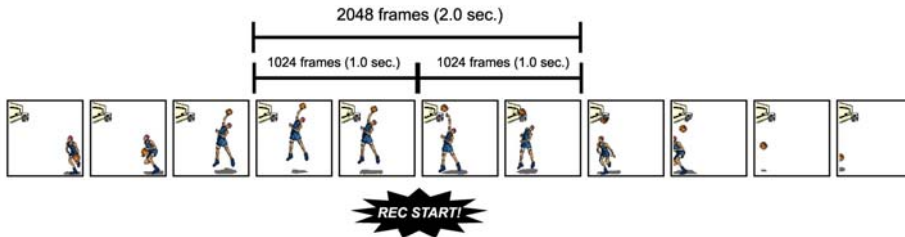

### 3.4.3. END Mode

END mode is a trigger mode where the content recorded immediately before the trigger is input is saved to memory. This mode is suitable for recording a high-speed phenomenon where it is hard to predict when the important action will start and stop. For example, in a situation with a maximum useable memory for two seconds of recording, the two seconds of high-speed video immediately before when the trigger was input are saved.



### 3.4.4. MANUAL Mode

MANUAL mode is a trigger mode, similar to CENTER mode, where the content recorded before and after the trigger is input is saved to memory, but the proportion of time before and after the trigger can be set as required. For example, in a situation with a maximum record time of two seconds, 0.5 seconds before and 1.5 seconds after the trigger is input are recorded and saved, a total of two seconds of high-speed video.



---

## 3.5. LOW LIGHT Mode

---

The more you increase the frame rate or shutter speed of the camera, the more the amount of light entering the camera decreases, making the displayed image darker. Low light mode is a function that temporarily increases the exposure time, making the displayed image easier to see to enable you to focus and setup camera.

## 3.6. White Balance Adjustment (Color Types Only)

---

On digital video cameras, photographing white as pure white is described as "having the appropriate white balance." On the system's color types as well, in order to take images with the correct color representation, the white balance must be adjusted for the color temperature of the light source used. The intensity of each color, R, G, and B, can be adjusted on this system. By adjusting the balance of those three colors to match the light source used, the appropriate white balance can be achieved. Two methods are available for adjusting the white balance, preset and user-editable white balance. These methods are explained in this section.

### 3.6.1. Using Preset White Balance (Color Types Only)

---

With the system, there are two types of white balance presets (5100K, 3100K) for use with common light sources. The suggested color temperature for these presets is listed below.

- 5100K (Daylight, Outdoors)
- 3100K (Halogen Light Source)

### 3.6.2. Using User White Balance (Color Types Only)

---

User white balance can be set in order to achieve the most appropriate white balance for the light source used with the system and the conditions during recording.

The values set here are stored in the camera body's internal memory as the user preset, and they can be loaded by selecting USER.

There are also two methods for setting user white balance, AUTO USER and EDIT USER.

## 3.7. Color Enhancement Function (Color Types Only)

Color types feature an image color enhancement setting. The image color enhancement level can be adjusted in five steps, including the OFF setting.

Display	Contents
OFF	Turns the color enhancement mode off
x 0.5 (LEVEL1)	S Sets x0.5 color enhancement
x 1 (LEVEL2)	S Sets x1 (default) color enhancement
x 1.5 (LEVEL3)	S Sets x1.5 color enhancement
x 2 (LEVEL4)	S Sets x2 color enhancement

## 3.8. LUT (Look-Up Table) Operations

The LUT (Look-Up Table) refers to a reference table that defines the relationship between the pixel brightness gradation of the original image data taken and the brightness gradation displayed on a computer screen or video monitor.

The system contains a hardware LUT function, and you can display the image data taken with improved contrast (light and dark sharpness) or make an object in the image stand out by emphasizing a specified gray level range.

The LUT in the system and the relationship between it and video output and the PC software is explained below.

### ! Caution

- When an image is saved with its brightness converted with the LUT, the image saved is the image that has had its brightness converted.

### 3.8.1. Using Preset LUT Patterns

Six preset LUT patterns have been prepared in advance on the system. Each of these patterns is explained in sequence in this section.

- ◆ DEF1: Gain 1x  
The input is always linear output.

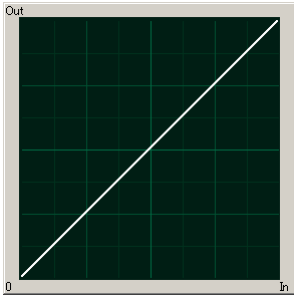

- ◆ DEF2: Gamma 0.8  
This LUT is 0.8 gamma correction. This LUT is used for normal conditions.

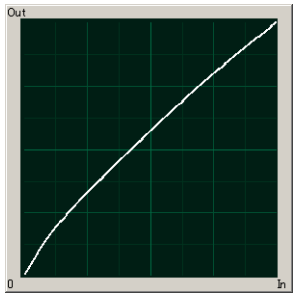

- ◆ DEF3: Gamma 0.6  
This LUT is 0.6 gamma correction.

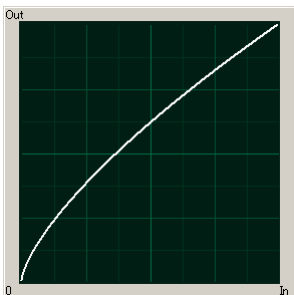

◆ DEF4: Gain 2x

The gain is doubled and you can display the dark areas of the image emphasized.

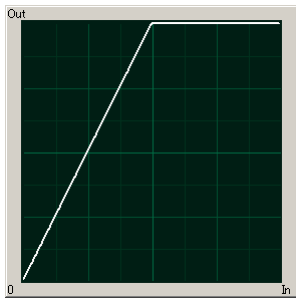

◆ DEF5: Gain 4x

The gain is quadrupled and you can display the dark areas of the image emphasized. This LUT emphasizes the dark portions even more than D4.

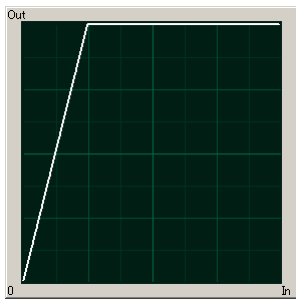

◆ DEF6: Reverse Gradation

The input gradation is reversed and then displayed.

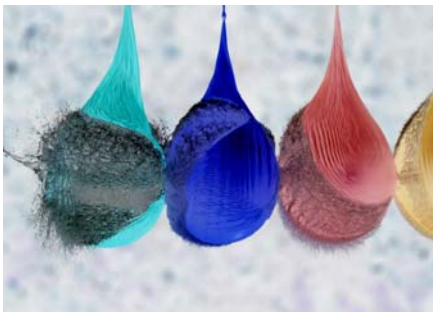
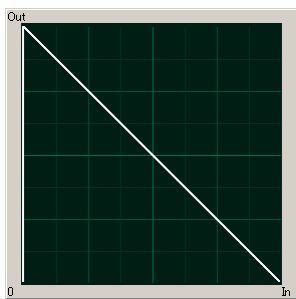

---

### 3.8.2. Using a Custom LUT

Creating a LUT pattern is done with PFV.

#### Reference

- For the creation method of a LUT pattern, refer to “Photron FASTCAM Viewer User’s Manual”.

## 3.9. Edge Enhancement Function

---

With the system's edge enhancement setting, you can enhance the edges in the recorded image in three steps.

Display	Contents
OFF	Edge enhancement off.
LEVEL1	Edge enhancement set to light.
LEVEL 2	Edge enhancement set to medium.
LEVEL 3	Edge enhancement set to heavy.

## **3.10. Input / Output Signal Types**

---

With the system, many signals can be input and output through the I/O cable. Signals that can be input and output from the I/O cable are listed below.



A signal other than the specified signal must not be input to the various connectors.  
Use extreme caution as there is a risk of damage to both the input device and the output device.

### **3.10.1. TRIG TTL IN Connector**

The system recognizes an external TTL signal as a trigger during the READY or ENDLESS recording state. Starting and stopping recording (in the selected recording mode) is controlled with this signal.

Input voltage is 0V to +10V (L level +1.0 or less, H level +2.8V to +10V), positive or negative polarity, pulse width is 100 ns or greater.

### **3.10.2. TRIG TTL OUT Connector**

A 5V TTL trigger signal is output for input to an external device.

### **3.10.3. TRIG SW IN Connector**

This trigger is input during the READY or ENDLESS recording state by contact between the BNC connector's shield and a center pin (switch closure). The center pin normally has voltage flowing through it. Use caution to avoiding contact with other pins.

### **3.10.4. SYNC IN Connector**

The system recognizes a TTL signal from other devices as a synchronization signal.

Input voltage is 0V to +10V (L level +1.0 or less, H level +2.8V to +10V), positive or negative polarity, pulse width is 100 ns or greater.

### 3.10.5. GENERAL IN Connector

The effect when a signal is input is described below, and can be optionally selected and set. The setting is made from the PFV.

The input voltage is 0V to +10V (L level +1.0 or less, H level +2.8V to +10V), positive or negative polarity, pulse width is 100 ns or greater.

TRIG POS/NEG	Inputs a TTL trigger signal.
READY POS/NEG	Inputs a change recording ready status signal (READY ON/OFF).

#### Reference

- To make the setting from PFV, refer to the “Photron FASTCAM Viewer User’s Manual”.

### 3.10.6. GENERAL OUT (1, 2) Connector

These are also BNC connectors. The signals below can be changed and output from the PFV.

(POS: positive polarity, NEG: negative)

SYNC POS/NEG	Outputs a vertical synchronization signal.
EXPOSE POS/NEG	Outputs the camera’s exposure period signal. * Outputs during both LIVE and recording.
REC POS/NEG	Outputs a signal during recording.
TRIG POS/NEG	Outputs the trigger signal the camera received.
READY POS/NEG	Outputs a signal that indicates the recording ready state.

#### Reference

- Refer to “3.13.2. GENERAL OUT Signal Settings”, page 40 for details.

## 3.11. Using External Triggers

With the system, you can record by receiving various trigger signals matched to the recording application. The trigger signals that can be used on the system are explained here, along with a description of how to use them.

### 3.11.1. Inputting an External Trigger Signal

The external trigger signals that can be used with the system and their input system are listed below. You can change External trigger signal input settings by PFV.

The signals input from the TRIG TTL IN and GENERAL IN connectors are explained in section "2.2.7. I/O Port Connector".

Connector Name (Input System)	Setting	Signal
TRIG TTL IN	TRIG POS	FET Input 0V - +10V (L level +1.0 or less, H level +2.8V to +10V), Positive Polarity
	TRIG NEG	FET Input 0V - +10V (L level +1.0 or less, H level +2.8V to +10V), Negative Polarity
GENERAL IN	TRIG POS	FET Input 0V - +10V (L level +1.0 or less, H level +2.8V to +10V), Positive Polarity
	TRIG NEG	FET Input 0V - +10V (L level +1.0 or less, H level +2.8V to +10V), Negative Polarity
TRIG SW IN	None	Contact signal

Set the signal type to be input to GENERAL IN from the PFV in advance.



Use caution not to input more than specified voltage to the TRIG TTL IN and GENERAL IN trigger signal inputs as there is a risk of damage to the equipment.

#### Reference

- For the setting method of the signal inputted into GENERAL IN, refer to "3.13.1. GENERAL IN Signal Settings", page 39.

◆ TRIG TTL IN / GENERAL TTL IN / TRIG SW IN Circuit Diagram

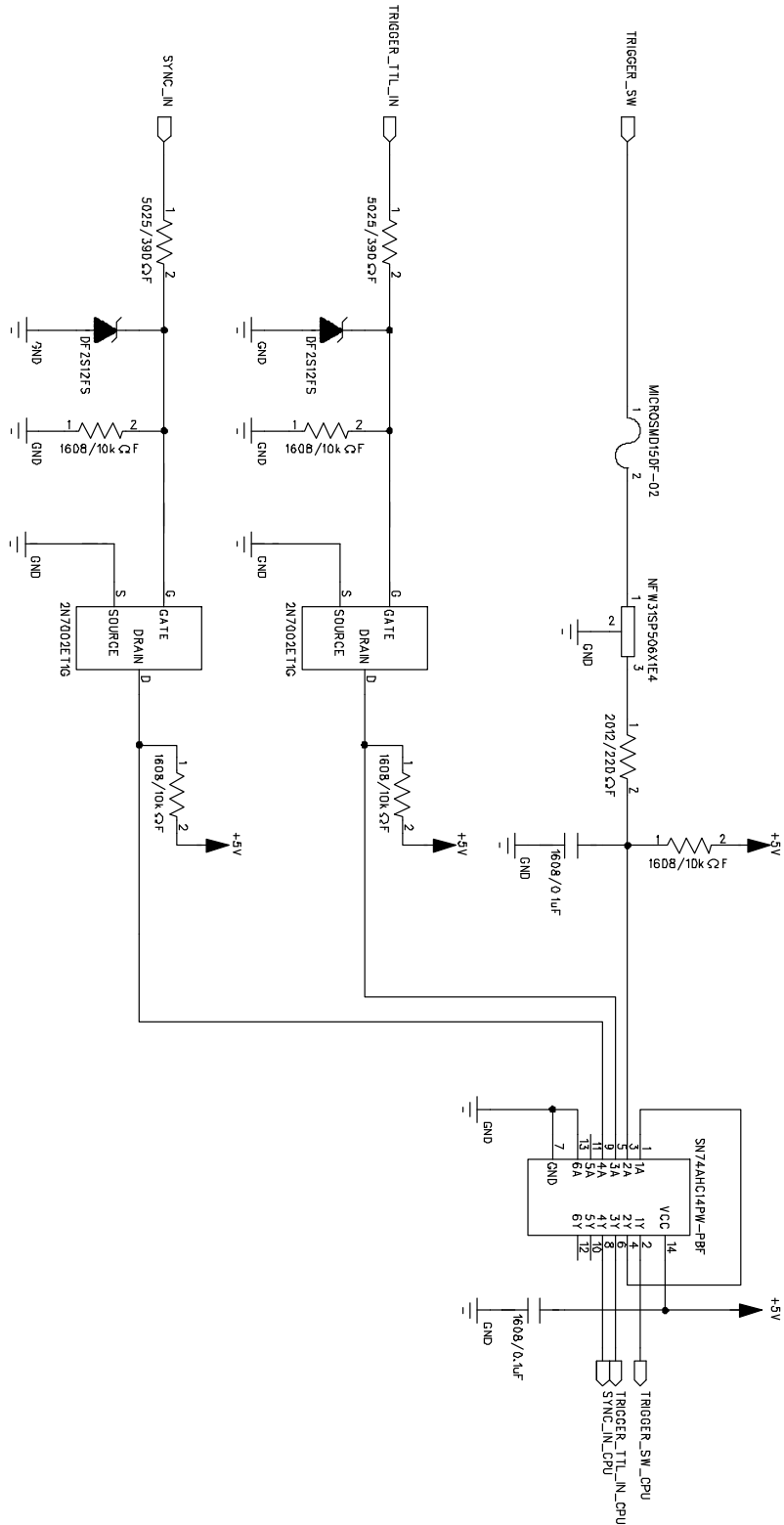

### 3.11.2. Outputting External Trigger Signals

With the system, you can externally output trigger signals. Output is performed with the TRIG TTL OUT connector's dedicated trigger output system provided by the system, and additionally, output can also be optionally set from the GENERAL OUT connector. You can change External trigger signal output settings by PFV.

Signal output is performed from the TRIG TTL OUT connector and the GENERAL OUT connector explained in section "2.2.7. I/O Port Connector".

The chart below summarizes the output systems and the signals that can be output.

Connector Name (Output System)	Setting	Signal Type	Delay Time
TRIG TTL OUT	TRIG POS	TTL, SW, SOFT, all TRIG pulse output CMOS (74ACT541 buffer) output, Positive Polarity.	Approx. 24 usec for TRIG SW IN
	TRIG NEG	TTL, SW, SOFT, all TRIG pulse output CMOS (74ACT541 buffer) output, Negative Polarity.	Approx. 85 ns for TRIG TTL IN, GENERAL IN
	TTL IN THRU POS	TRIG TTL IN through output CMOS (74ACT541 buffer) output, Positive Polarity.	Approx. 85 ns for TRIG TTL IN
	TTL IN THRU NEG	TRIG TTL IN through output CMOS (74ACT541 buffer) output, Negative Polarity.	
GENERAL OUT	TRIG POS	TTL, SW, SOFT, all TRIG pulse output CMOS (74ACT541 buffer) output, Positive Polarity.	Approx. 24 usec for TRIG SW IN
	TRIG NEG	TTL, SW, SOFT, all TRIG pulse output CMOS (74ACT541 buffer) output, Negative Polarity.	Approx. 85 ns for TRIG TTL IN, GENERAL IN



#### Important

- When a trigger signal is output to GENERAL OUT, set the signal to be output from the PFV in advance before using it.

## 3.12. Using External Synchronization Signals

An external synchronization mode to synchronize to an external signal is provided on the system. By using an external synchronization signal, recording can be conducted using multiple cameras to synchronize the timing of the shots or to also synchronize the shots with external measuring devices and lighting. The procedure and precautions for using the external synchronization signal are explained below.

### 3.12.1. Inputting an External Synchronization Signal

An external synchronization signal can be input with the system. See the chart below for external synchronization input settings.

Display	Contents	Signal (Input Signal Conditions)
OFF	Sets external synchronization off, operates independently.	(none)
ON CAM POS	Synchronizes to a positive polarity signal from the system.	FET Input 0V - +10V (L level +1.0 or less, H level +2.8V to +10V), Positive Polarity
ON CAM NEG	Synchronizes to a negative polarity signal from the system.	FET Input 0V - +10V (L level +1.0 or less, H level +2.8V to +10V), Negative Polarity

### 3.12.2. Outputting an External Synchronization Signal

The system can externally output a synchronization signal. Output of the external synchronization signal is performed from the GENERAL OUT connector explained in section "2.2.7. I/O Port Connector". See the chart below for external synchronization output settings.

Display	Contents	Signal Type	Delay Time
SYNC POS	Outputs a positive polarity vertical synchronization signal.	CMOS (74ACT541 buffer) output, positive polarity	Approx. 253nsec
SYNC NEG	Outputs a negative polarity vertical synchronization signal.	CMOS (74ACT541 buffer) output, negative polarity	Approx. 288nsec

### 3.12.3. Synchronization with a variable frequency

When synchronizing with a varying input frequency signal, the frame rate and resolution specified before recording will be kept as a maximum value, and the camera frequency can alternate to a minimum of about 60Hz(50Hz) following to the input signal, even under the recording mode.

#### Caution

- AThe camera runs as 48Hz when external sync signal is not inputted.

### 3.12.4. Synchronizing Multiple FASTCAM SA8 Systems(Multiple Unit Synchronized Recording)

The system can perform synchronized recording by synchronizing multiple units using external.

◆ Synchronization input/output

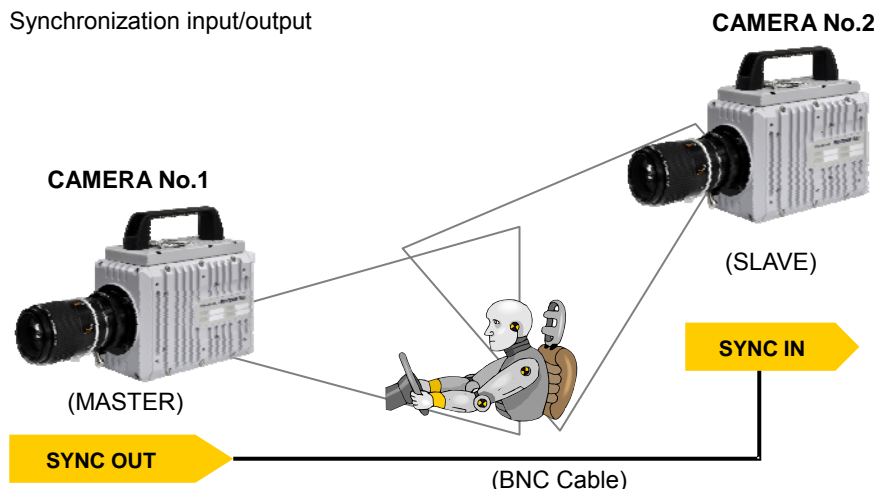

Synchronized recording settings using the system are made with PFV. The conceptual settings when performing synchronized recording using two systems are explained here. First, decide which camera to make the master camera (outputs the synchronization signal) and the slave camera (receives the synchronization signal) from the two systems to use for synchronized recording.

◆ Setting the Master Camera (Outputs Synchronization)

Set the signal output for the master camera which will output the synchronization signal. Synchronization signal settings are made with PFV.

■ For PFV (Standard)

1. Verify that the camera mode is in LIVE mode (the image displayed is passed through from the camera). If the system is in a mode other than LIVE mode, check "Live" on the camera control panel.
2. Select I/O on the left tree from "Camera Option" on the camera control panel.
3. Set "GENERAL OUT1".

■ For the LCD Remote Controller (Optional)

1. Press the LCD remote controller's MENU key and the menu list is displayed.
2. Select GENERAL OUT1 from the SYNC IN/OUT submenu with the LCD remote controller's ARROW keys and press the ENTER key.
3. From the menu, select the signal to output from the master camera's GENERAL OUT1 connector. Move the cursor to the SYNC POS item with the ARROW keys and press the ENTER key to select.
4. The master camera is set to output a positive polarity vertical synchronization signal from its GENERAL OUT1 connector.

---

---

◆ **Setting the Slave Camera (Receives the Synchronization Signal)**

Next, set the synchronization signal input for the slave camera which will receive the synchronization signal supplied by the master camera. Synchronization signal settings are made with the "LCD remote controller (optional)" or PFV.

■ **For PFV (Standard)**

1. Verify that the camera mode is in LIVE mode (the image displayed is passed through from the camera). If the system is in a mode other than LIVE mode, check "Live" on the camera control panel.
2. Select I/O on the left tree from "Camera Option" on the camera control panel.
3. Set SYNC IN to "ON CAM POS".

■ **For the LCD Remote Controller (Optional)**

1. Input the slave camera's synchronization. Connect the slave camera's SYNC IN connector with the master camera's GENERAL OUT1 connector using a BNC cable. When the synchronization signal is input to the SYNC IN connector, the SYNC IN LED (yellow) on the rear of the slave camera illuminates.
2. Set the synchronization signal type that slave camera will receive. Press the LCD remote controller's MENU key and the menu list is displayed.
3. Select SYNC IN from the SYNC IN/OUT submenu with the LCD remote controller's ARROW keys and press the ENTER key.
4. The output previously set on the master camera has positive polarity (POSITIVE), therefore it is necessary to make the setting on the slave camera controller the same, positive polarity (POSITIVE). Move the cursor to the ON CAM POS item with the ARROW keys and press the ENTER key to select.

 **Important**

- If steps, 2 to 3 are completed when no synchronization signal is being input, the camera will not operate normally. As detailed in the procedure, make the settings when the signal is being input.

---

### 3.12.5. Synchronizing the System with Other Cameras (Mixed Device Synchronized Recording)

---

Using the function (frame rate synchronization recording) in the previous section, "3.12.4. Synchronizing Multiple FASTCAM SA8 Systems(Multiple Unit Synchronized Recording)", mixed-type synchronized recording can be performed with Photron's other high-speed cameras (except for some older products).

◆ Basic Process

1. Decide the master camera (the source of the synchronization signal) and the slave camera (the camera that will operate according to the synchronization signal from the master). Basically, by making the master camera the camera with the lowest maximum frame rate that can be set, you can avoid setting a synchronization signal speed the slave camera cannot receive.
2. Connect the master camera's V-SYNC output connector to the slave camera's V-SYNC input connector with a BNC cable, select the synchronization signal output polarity on the master camera, and then set the slave camera to be operated by that signal.

 Reference

- For camera types that can perform synchronized recording or for detailed instructions on making the settings, contact Photron at the contact information in "7.1. Contact Information"

## 3.13. GENERAL Signal Settings

### 3.13.1. GENERAL IN Signal Settings

Details of the signals output from the GENERAL OUT connector explained in section “3.10. Input / Output Signal Types” are shown in the chart below.

Display	Contents	Signal (Input Signal Conditions)
TRIG POS	Inputs a positive polarity trigger signal.	FET Input 0V - +10V (L level +1.0 or less, H level +2.8V to +10V), Positive Polarity
TRIG NEG	Inputs a negative polarity trigger signal.	FET Input 0V - +10V (L level +1.0 or less, H level +2.8V to +10V), Negative Polarity
READY POS	Inputs a positive polarity READY signal. READY ON/OFF is switched by a pulse input.	FET Input 0V - +10V (L level +1.0 or less, H level +2.8V to +10V), Positive Polarity
		FET Input 0V - +10V (L level +1.0 or less, H level +2.8V to +10V), Negative Polarity
READY NEG	Inputs a negative polarity READY signal. READY ON/OFF is switched by a pulse input.	FET Input 0V - +10V (L level +1.0 or less, H level +2.8V to +10V), Positive Polarity
		FET Input 0V - +10V (L level +1.0 or less, H level +2.8V to +10V), Negative Polarity



When using the camera as a part of a system, verify the characteristics of the input signals before using them.

### 3.13.2. GENERAL OUT Signal Settings

Details of the signals output from the GENERAL OUT connector explained in section “3.10. Input / Output Signal Types” are shown in the chart below. There are three GENERAL OUT connectors and individual settings can be made for each connector.

Display	Contents	Signal Type
SYNC POS	SYNC POS Outputs a positive polarity vertical synchronization signal.	+5V CMOS Output Positive Polarity
SYNC NEG	SYNC NEG Outputs a negative polarity vertical synchronization signal.	+5V CMOS Output Negative Polarity
EXPOSE POS	Outputs the camera head's image sensor's exposure interval at H level.	+5V CMOS Output Positive Polarity
EXPOSE NEG	Outputs the camera head's image sensor's exposure interval at L level.	+5V CMOS Output Negative Polarity
REC POS	REC POS Outputs an interval signal during recording at H level.	+5V CMOS Output Positive Polarity
REC NEG	REC NEG Outputs an interval signal during recording at L level.	+5V CMOS Output Negative Polarity
TRIG POS	Outputs the trigger signal received by the camera at H level.	+5V CMOS Output Positive Polarity
TRIG NEG	Outputs the trigger signal received by the camera at L level.	+5V CMOS Output Negative Polarity
READY POS	Outputs a signal at H level during the trigger wait state. (READY in START mode.) Only valid during START, CENTER, END, and MANUAL modes.	+5V CMOS Output Positive Polarity
READY NEG	Outputs a signal at L level during the trigger wait state. (ENDLESS recording state in CENTER, END, MANUAL) Only valid during START, CENTER, END, and MANUAL modes.	+5V CMOS Output Negative Polarity



When using as a part of a system, verify the characteristics of the output signals before using them.

### 3.14. Signal Delay

With the system, you can set the signal delay time or pulse width for the various signals that are input and output. Pulse width and delay settings for the various signals to input/output are made with PFV. The content of each setting is listed in the chart below.

Setting Item	Setting Range (Value)
TRIG TTL IN DELAY	0-60 (s) 100 ns units
SYNC IN DELAY	0-1/frame rate (s) 100 ns units
GENERAL IN DELAY	0-60 (s) 100 ns units
TRIG OUT WIDTH	0-1 (ms) 100 ns units
SYNC OUT DELAY	0-1/frame rate (s) 100 ns units
SYNC OUT WIDTH	0-500 (us), 1/frame rate (s) at 2000 fps or higher 100 ns units
EXPOSE OUT DELAY	0-1/frame rate (s) 100 ns units
SYNC OUT TIMES	0.5, 1, 2, 4, 6, 8, 10, 20, 30 (* x1 is standard output)

◆ SYNC OUT TIMES

Outputs SYNC (vertical synchronization signal) from SYNC OUT that is X times SYNC.

Example: For a frame rate of 1000 fps, SYNC OUT TIMES setting of 2.

1000 fps Synchronization Signal

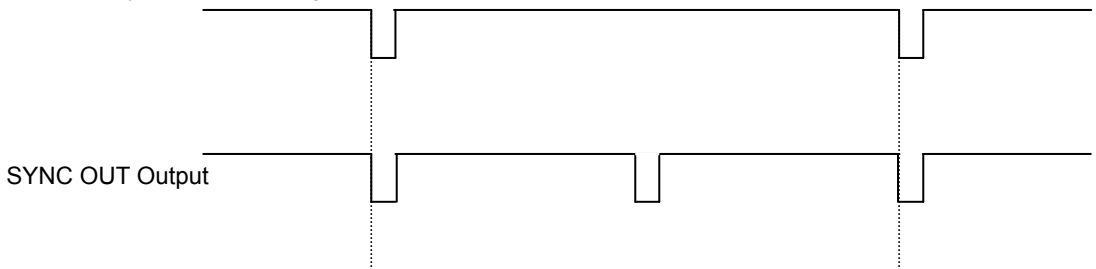

Example: For a frame rate of 1000 fps, SYNC OUT TIMES setting of 4.

1000 fps Synchronization Signal

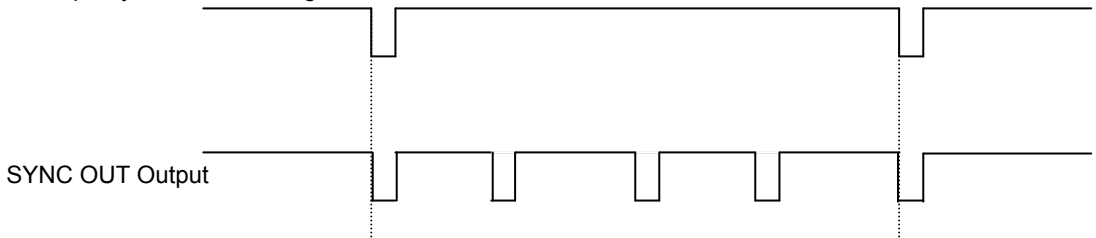

**Caution**

- An accurate frequency is output, but when SYNC OUT TIMES is set to a large value with a high frame rate, the setting may result in frequency errors.

### 3.15. Using USER SW (Programmable Switch)

There is a switch that can be set on the back of the system. A setting for the switch is made from the PFV and it can be assigned a different function. As an example, setting the "USER SW" switch on the back of the camera body is explained here.

Setting	Explanation
OFF	Does not assign a function.
Change Frame Rate	Raises the frame rate
Change Resolution	Lowers the resolution
Change Shutter Speed	Increases the shutter speed.
Change Trigger Mode	Changes the trigger mode.
Fitting image	Adjusts the size of the image displayed on the video output to be the maximum for the current resolution.
Status Display	Displays the status of camera settings on the video output.
Switch LIVE/MEMORY	Switches between LIVE and MEMORY states.
Record Ready	Sets the record ready state.
Record	Starts recording.
Low-Light	Turns low-light mode ON/OFF.

## 3.16. IRIG Time Code (External Time Synchronization)

The system supports IRIG-B input and can add an IRIG code to each recorded frame. The sample timing for the IRIG code is once each frame.

The recorded IRIG code is displayed on the VIDEO display or with the “Photron FASTCAM VIEWER” software.

### ◆ IRIG Code Input Specification

Connector	BNC
Code Format	IRIG-B (122) Analog
Amplitude	1.0Vp-p min,8.0Vp-p max
Modulation Ratio	3:1 to 6:1

### Supplement

- IRIG Time Code is used when synchronizing a camera with external equipment in time. It is a convenient function when apparatus is physically separated.
- When the IRIG code is being input, the IRIG code is displayed in white, and is displayed to the left.
- The IRIG offset time is also displayed below it. When the IRIG code is not being input, the IRIG code is displayed in grey. At that time, the counter is the camera’s internal counter and it continues to count.

### Caution

- **Limitation of use of IRIG code**  
With the Image Trigger function, IRIG code cannot be used when the specified number of frames is 32 or fewer in RANDOM CENTER or RANDOM MANUAL trigger mode.

### 3.17. 8bit Recording Mode

---

Since the image sensor of 12 bits specification is being used for this product, it is usually recorded at 12 bits. By using 8 bits Recording Mode Mode, it is possible to record by 8 bits.

When data is recorded in the 8-bit mode, the amount of data is smaller than in 12-bit mode. Therefore, it is possible to record for a longer amount of time.

8bit Recording Mode setting can be made with the "Remote controller (optional)" or PFV.

#### Reference

- For the details of a 8 bit Recording Mode setup, refer to「5.1.7. Recordable Image Count/Resolution(8bit)」,Page 59.

# Chapter. 4 **Connecting a PC**

---

## **4.1. Connecting the Gigabit Ethernet Interface to a PC**

## 4.1. Connecting the Gigabit Ethernet Interface to a PC

The system can have the operation of its functions performed from a PC using the Gigabit Ethernet interface. This section explains the required setup when connecting the system to a PC.

To connect a PC to the system, connect the system to a commercially available 1000BASE-T-compatible interface board with a LAN cable. For the LAN cable, prepare a UTP or STP Cat 5e (enhanced category 5) or higher LAN cable. (UTP: unshielded, STP: shielded)  
The maximum cable length between the PC and the system is, compliant to the 1000BASE-T specification, up to 100 m. One PC can connect to a maximum of 64 Photron Gigabit Ethernet interface equipped cameras using a hub. When connecting multiple devices, connect through a switching hub that can connect at 1000BASE-T. The maximum length of the cable that connects the system (or PC) to the switching hub is also 100 m.



### Important

- The system is only 1000BASE-T compatible. When using a PC compatible with only 10BASE-T or 100BASE-TX, the PC must be connected through a 10BASE-T, 100BASE-TX, and 1000BASE-T compatible switching hub.
- There are two connectors equipped for prospective additional functions. Either of the GigabitEthernet connectors is available for use.
- The system's factory default IP address is below:

```
IP ADDRESS > GIGABIT ETHER1    192.168.0.10
                GIGABIT ETHER2    192.168.1.10
NETMASK >    GIGABIT ETHER 1    255.255.255.0
                GIGABIT ETHER 2    255.255.255.0
GATEWAY ADDRESS > 0.0.0.0
PORT > 2000 (Fixed, not changeable)
```



### Supplement

- Photron recommends using an STP cable over long distances or in noisy locations.



### Reference

- For the setting method of IP address for camera system, refer to “4.1.2. Setting the IP Address”, page 47.
- For the setting method of control PC, refer to “Photron FASTCAM Viewer User's Manual”.

---

### **4.1.1. Connecting the System and a PC**

Connect the LAN cable to the system as shown below.



Insert the LAN cable into the "GIGABIT ETHER 1" connector.

### **4.1.2. Setting the IP Address**

#### **! Caution**

- When connecting the system to a PC or when connecting other Gigabit Ethernet interface compatible Photron cameras, set each of those devices to a different IP address. Also, when connecting the system to an existing network, do not use IP addresses that are already in use on the network.

#### **Reference**

- For the procedure for setting the IP address of the system, refer to the "Photron FASTCAM Viewer User's Manual".

### **4.1.3. Using DHCP (Dynamic Host Configuration Protocol)**

The system is compatible with DHCP. In an environment where DHCP is used, the system's IP address can be acquired from the DHCP server.

#### **Reference**

- For details, refer to the "Photron FASTCAM Viewer User's Manual".

#### **4.1.4. Connecting Multiple Systems and a PC**

With PFV, the system's control software, one PC can connect to and control multiple FASTCAM SA5, FASTCAM SA4, FASTCAM 2, FASTCAM 1.1, FASTCAM SA7, FASTCAM SA8, FASTCAM APX-RS, and FASTCAM MH4-10K systems.

##### **! Caution**

- When connecting to multiple systems, set the IP address of each one to a unique setting.

#### **4.1.5. Gigabit Ethernet Interface Initialization**

When encounter problems on communication between the control software PFV and the camera, please perform the following steps to initialize the Gigabit Ethernet interface.

1. Press and hold on the USER SW (Programmable Switch) on the rare of camera for about 10~15 seconds.
2. When the LEDs blink from left to right and then from right to left alternately, it indicates the initialization operation is accomplished.

##### **! Caution**

- Pressing and holding on the USER SW (Programmable Switch) for more than 15 seconds will result in an IP Address Initialization.

#### **4.1.6. Camera IP Address Initialization**

In some circumstance when the IP address is changed, and the new IP address is not explicit, an IP Address Initialization operation is recommended. In this case, the IP address will be reset to 192.168.0.10 as the factory settings.

1. Press and hold on the USER SW (Programmable Switch) on the rare of camera for over 15 seconds.
2. When the LEDs blink from left to right and then from right to left alternately, it indicates the initialization operation is accomplished.

# Chapter. 5 **Product Specifications**

---

## **5.1. Specifications**

## **5.2. Dimensions**

## 5.1. Specifications

### 5.1.1. Product Specifications

		30K type	15K type
Image Sensor		CMOS image sensor	
Sensor Resolution (full)		1,280x1,024 pixels	
Max. Full Frame Rate		3,500 fps (1,280x1,024)	2,000 fps (1,280x1,024)
Max. Frame Rate		30,000 fps (320x256)	15,000 fps (320x256)
Min. Frame Rate		50 fps (1,280x1,024)	
Sensor Size		12.80 mm x 10.24 mm	
Pixel Size		10m x 10um	
Recording Color Depth	Monochrome	12-bit A/D conversion	
	Color	36-bit A/D conversion (RGB each 12-bit) Bayer color filter method	
Shutter		Electronic shutter	
Recording Method		IC memory	
Recording Memory Amount		4 GB standard, 8 GB maximum	
Trigger Method		Start, Center, END, Manual	
Gain Control		Hardware LUT on camera, controllable via software	
Image Output Customization		Customizable LUT, brightness is changeable	
Ext. Sync. Input Signal		5Vp-p negative polarity/positive polarity (switchable)	
Ext. Sync. Output Signal		5Vp-p negative polarity/positive polarity (switchable)	
Trigger Input Signal		TTL, contact	
Other Output Signals		Other timing signal outputs	
External Control		digital I/F (PC)	
Video Output Signal		NTSC / PAL	
Digital Interface		Gigabit Ethernet (1000BASE-T) x2	

## 5.1.2. General Specifications

Environment Conditions	
Storage Temperature	-20°C ~ 60°C (No Condensation)
Storage Humidity	Below 85% (No Condensation)
Guaranteed Operating Temperature	0~40°C (No Condensation)
Guaranteed Operating Humidity	Below 85% (No Condensation)
Pollution degree	Degree 2 according to IEC60664-1
Overvoltage category	Category II according to IEC60664-1
Dimensions	
Camera Body	135 (H) × 102 (W) × 195.2 (D) mm excluding protrusions
Camera + Memory Battery	135 (H) × 138 (W) × 195.2 (D) mm excluding protrusions
DC Power Supply	
Power Supply Voltage	22V ~ 32V
Power Consumption	65VA
Weight	
Camera Body	3.6kg



Photron has verified two types of AC cables, type A (standard for Japan, USA, Canada, etc.) and type SE (standard for Germany, France, etc.). However, when those cables cannot properly receive power when plugged in, use the proper AC cable for the region's standards and verify that AC cable works properly.

For inquiries regarding the recommended AC cable for each region, contact that region's Photron branch office or the distributor.

## 5.1.3. AC / DC Adaptor

Manufacturer		FSP Group Inc. (Brand Name : PROTEK)
Type		PMP150-14-K20
Rating	Input	AC100-240V , 47-63Hz , 1.63-0.7A
	Output	DC24V , 6.25A
Dimensions		49.7 (H) × 82 (W) × 207.6 (D) mm excluding protrusions
Weight		970g

### **5.1.4. Options**

User Options
Remote Keypad
4 output trigger box
Spare power supply connector (for a custom cable)
Dust-proof cover for the LAN connector
Dedicated carry case
Memory backup battery



### 5.1.5. Frame Rate and Resolution

FASTCAM SA8 type 30K (1,280 x 1,024 to 1,024 x 768)

frame rate(fps) \ Image Size	1,280 x 1,024	1,280 x 768	1,280 x 720	1,280 x 640	1,280 x 512	1,280 x 256	1,280 x 128	1,024 x 1,024	1,024 x 768
50(PAL)	○	○	○	○	○	○	○	○	○
60	○	○	○	○	○	○	○	○	○
125	○	○	○	○	○	○	○	○	○
250	○	○	○	○	○	○	○	○	○
500	○	○	○	○	○	○	○	○	○
1,000	○	○	○	○	○	○	○	○	○
2,000	○	○	○	○	○	○	○	○	○
2,500	○	○	○	○	○	○	○	○	○
3,000	○	○	○	○	○	○	○	○	○
3,500	○	○	○	○	○	○	○	○	○
4,000		○	○	○	○	○	○		○
5,000			○	○	○	○	○		
6,000					○	○	○		
7,500						○	○		
10,000						○	○		
15,000							○		
20,000							○		
30,000									

The circle indicates a possible setting.

FASTCAM SA8 type 30K (960 x 720 to 320 x 256)

Image Size frame rate(fps)	960 x 720	896 x 896	800 x 800	800 x 600	800 x 400	640 x 584	512 x 512	512 x 384	320 x 256
50(PAL)	○	○	○	○	○	○	○	○	○
60	○	○	○	○	○	○	○	○	○
125	○	○	○	○	○	○	○	○	○
250	○	○	○	○	○	○	○	○	○
500	○	○	○	○	○	○	○	○	○
1,000	○	○	○	○	○	○	○	○	○
2,000	○	○	○	○	○	○	○	○	○
2,500	○	○	○	○	○	○	○	○	○
3,000	○	○	○	○	○	○	○	○	○
3,500	○	○	○	○	○	○	○	○	○
4,000	○	○	○	○	○	○	○	○	○
5,000	○	○	○	○	○	○	○	○	○
6,000				○	○	○	○	○	○
7,500				○	○	○	○	○	○
10,000					○		○	○	○
15,000									○
20,000									○
30,000									○

The circle indicates a possible setting.

FASTCAM SA8 type 15K (1,280 x 1,024 to 1,024 x 768)

frame rate(fps)	Image Size	1,280	1,280	1,280	1,280	1,280	1,280	1,280	1,024	1,024
		x 1,024	x 768	x 720	x 640	x 512	x 256	x 128	x 1,024	x 768
50(PAL)		○	○	○	○	○	○	○	○	○
60		○	○	○	○	○	○	○	○	○
125		○	○	○	○	○	○	○	○	○
250		○	○	○	○	○	○	○	○	○
500		○	○	○	○	○	○	○	○	○
1,000		○	○	○	○	○	○	○	○	○
2,000		○	○	○	○	○	○	○	○	○
2,500			○	○	○	○	○	○		○
3,000					○	○	○	○		○
3,500						○	○	○		
4,000							○	○		
5,000							○	○		
6,000							○	○		
7,500								○		
10,000										
15,000										
20,000										
30,000										

The circle indicates a possible setting.

FASTCAM SA8 type 15K (960 x 720 to 320 x 256)

Image Size frame rate(fps)	960 x 720	896 x 896	800 x 800	800 x 600	800 x 400	640 x 584	512 x 512	512 x 384	320 x 256
50(PAL)	○	○	○	○	○	○	○	○	○
60	○	○	○	○	○	○	○	○	○
125	○	○	○	○	○	○	○	○	○
250	○	○	○	○	○	○	○	○	○
500	○	○	○	○	○	○	○	○	○
1,000	○	○	○	○	○	○	○	○	○
2,000	○	○	○	○	○	○	○	○	○
2,500	○	○	○	○	○	○	○	○	○
3,000	○	○	○	○	○	○	○	○	○
3,500				○	○	○	○	○	○
4,000				○	○	○	○	○	○
5,000					○	○	○	○	○
6,000					○			○	○
7,500								○	○
10,000									○
15,000									○
20,000									
30,000									

The circle indicates a possible setting.

### 5.1.6. Recordable Image Count/Resolution(12bit)

#### FASTCAM SA8 type 30K

Resolution	FrameRate
1,280×1,024	3,500 fps
1,280×768	4,000 fps
1,280×720	5,000 fps
1,280×512	6,000 fps
1,280×256	10,000 fps
1,280×128	20,000 fps
320×256	30,000 fps
1,024×1,024	3,500 fps
896×896	5,000 fps
800×600	7,500 fps
512×512	10,000 fps

Memory 4GB type		Memory 8GB type	
Rec time (second)	Rec frames (frame)	Rec time (second)	Rec frames (frame)
0.622	2,180	1.247	4,365
0.726	2,907	1.455	5,820
0.620	3,101	1.241	6,208
0.726	4,361	1.455	8,730
0.872	8,722	1.746	17,460
0.872	17,444	1.746	34,920
1.162	34,888	2.328	69,841
0.778	2,725	1.559	5,456
0.712	3,560	1.425	7,126
0.793	5,954	1.589	11,919
1.090	10,902	2.183	21,825

#### FASTCAM SA8 type 15K

Resolution	FrameRate
1,280×1,024	2,000 fps
1,280×768	2,500 fps
1,280×640	3,000 fps
1,280×256	6,000 fps
1,280×128	7,500 fps
320×256	15,000 fps
1,024×1,024	2,000 fps
896×896	3,000 fps
800×600	4,000 fps
512×384	7,500 fps

Memory 4GB type		Memory 8GB type	
Rec time (second)	Rec frames (frame)	Rec time (second)	Rec frames (frame)
1.090	2,180	2.182	4,365
1.162	2,907	2.328	5,820
1.162	3,488	2.328	6,984
1.453	8,722	2.910	17,460
2.325	17,444	4.656	34,920
2.326	34,888	4.656	69,841
1.362	2,725	2.728	5,456
1.186	3,560	2.375	7,126
1.489	5,954	2.980	11,919
1.938	14,536	3.880	29,100

## 5.1.7. Recordable Image Count/Resolution(8bit)

### FASTCAM SA8 type 30K

Resolution	FrameRate
1,280×1,024	3,500 fps
1,280×768	4,000 fps
1,280×720	5,000 fps
1,280×512	6,000 fps
1,280×256	10,000 fps
1,280×128	20,000 fps
320×256	30,000 fps
1,024x1,024	3,500 fps
896x896	5,000 fps
800x600	7,500 fps
512x512	10,000 fps

Memory 4GB type		Memory 8GB type	
Rec time (second)	Rec frames (frame)	Rec time (second)	Rec frames (frame)
0.934	3,272	1.871	6,549
1.090	4,363	2.183	8,732
0.930	4,654	1.862	9,314
1.090	6,545	2.183	13,099
1.309	13,091	2.619	26,198
1.309	26,182	2.619	52,396
1.745	52,364	3.493	104,793
1.168	4,091	2.339	8,187
1.068	5,343	2.139	10,693
1.191	8,936	2.384	17,884
1.636	16,364	3.274	32,748

### FASTCAM SA8 type 15K

Resolution	FrameRate
1,280×1,024	2,000 fps
1,280x768	2,500 fps
1,280×640	3,000 fps
1,280×256	6,000 fps
1,280×128	7,500 fps
320×256	15,000 fps
1,024x1,024	2,000 fps
896x896	3,000 fps
800x600	4,000 fps
512x384	7,500 fps

Memory 4GB type		Memory 8GB type	
Rec time (second)	Rec frames (frame)	Rec time (second)	Rec frames (frame)
1.636	3,272	3.274	6,549
1.745	4,363	3.492	8,732
1.745	5,236	3.493	10,479
2.181	13,091	4.366	26,198
3.490	26,182	6.986	52,396
3.490	52,364	6.986	104,793
2.045	4,091	4.093	8,187
1.781	5,343	3.564	10,693
2.234	8,936	4.471	17,884
2.909	21,818	5.821	43,664

### **5.1.8. Shutter Speed List**

Setting Value
1/125
1/250
1/500
1/1,000
1/1,600
1/2,000
1/2,500
1/2,857
1/3,000
1/3,333
1/4,000
1/5,000
1/5,556
1/6,000
1/6,250
1/7,000
1/7,143
1/8,000
1/9,000
1/10,000
1/12,500
1/15,000
1/16,777
1/20,000
1/25,000
1/30,000
1/40,000
1/45,000
1/50,000
1/60,000
1/70,000
1/80,000
1/90,000
1/100,000

## 5.2. Dimensions

### 5.2.1. Camera Body

All dimensions are in millimeters (mm) – 25.4 mm equals one inch. These diagrams are not shown to scale.

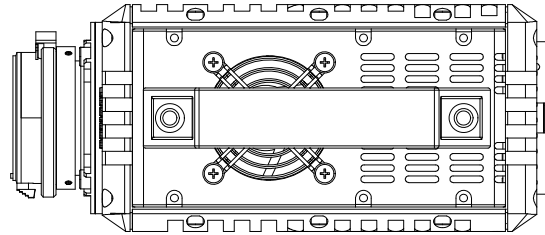

Top

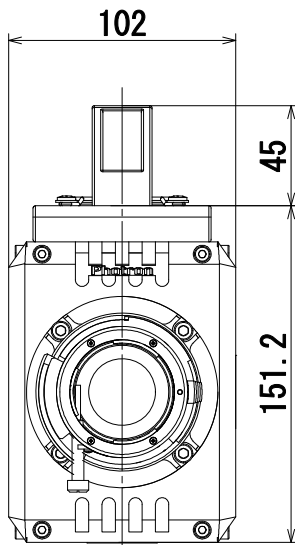

Front

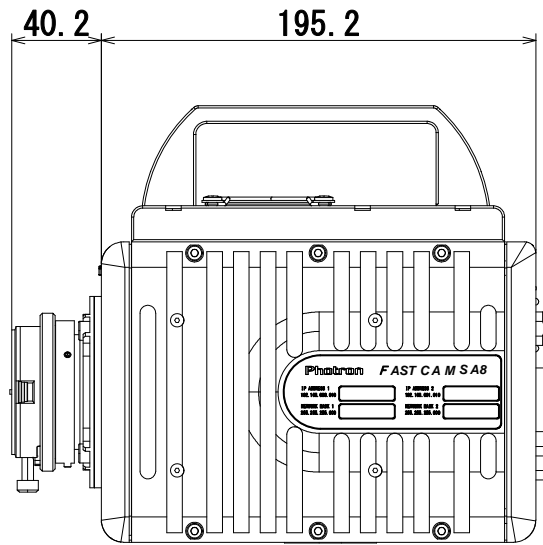

Side

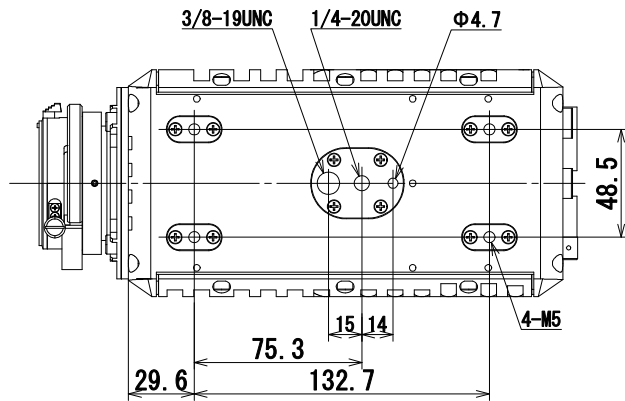

Bottom

### 5.2.2. AC / DC Adaptor

All dimensions are in millimeters (mm) – 25.4 mm equals one inch. These diagrams are not shown to scale.

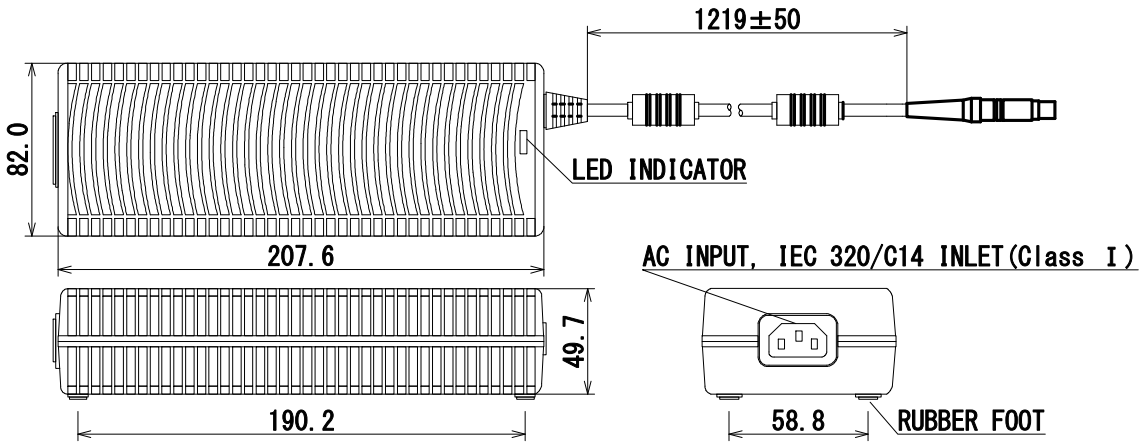

### 5.2.3. Memory Backup Battery

(mm)

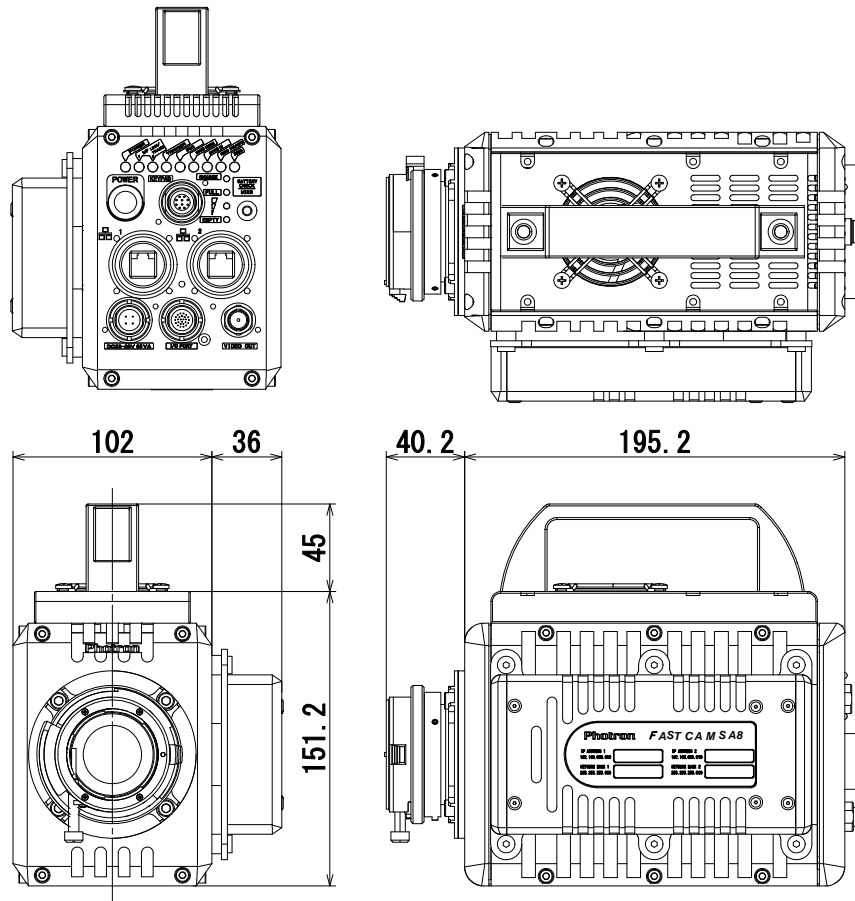

## 5.2.4. Remote Keypad (Option)

(mm)

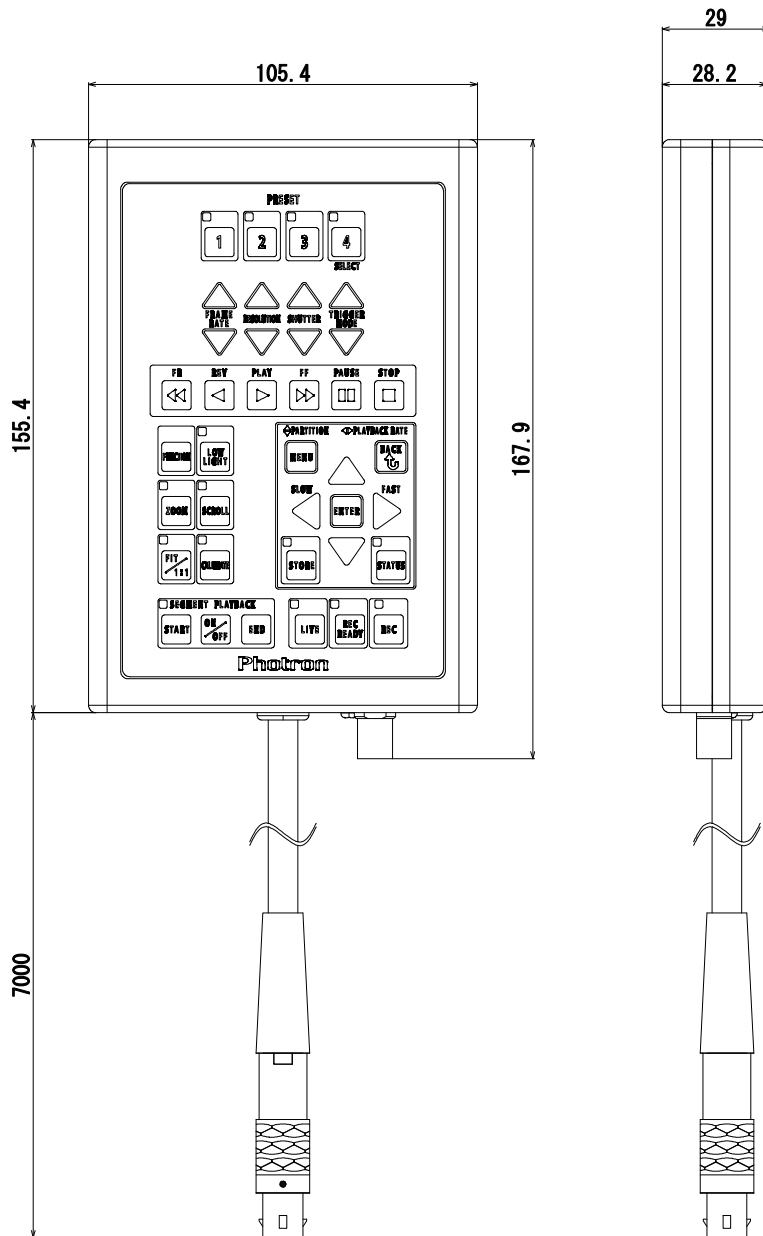



# Chapter. 6 **Warranty**

---

## **6.1. About the Warranty**

## 6.1. About the Warranty

---

This system has been shipped having undergone rigorous testing. However, in the unlikely event that it malfunctions due to a manufacturing defect, it will be repaired, at no charge, within the warranty period.

### ◆ Warranty Exceptions

The following exceptions will result in fee-based repair, even within the warranty period.

1. Damage or malfunction as a result of fire, earthquake, water damage, lightning, other natural disasters, pollution, or the effects of abnormal voltage.
2. Damage or malfunction as a result of dropping or mishandling during shipment or when moving after purchase or misuse.
3. Consumable goods (cables)
4. When repair, adjustment, or alternation done by an entity other than Photron service has been performed on the system, or damage or malfunction that is determined to be attributed to a fault in the use the product.

For inquires related to malfunction, contact the dealer where the product was purchased, or the nearest Photron office.



### Reference

- For inquires related to our product, refer to "7.1. Contact Information", page 68.

# Chapter. 7 **Contacting Photron**

---

## **7.1. Contact Information**

## 7.1. Contact Information

For inquiries related to PFV, contact Photron at the contact information listed below. Additionally, the following items will be verified when inquiring, so please prepare them in advance.

Items Verified	Concrete Example
Contact Information	Company, school or organization name, customer contact name, contact phone number, contact e-mail address.
Product Name	FASTCAM SA8
Serial Number	Check on the nameplate seal.
Condition of the system and what is known about it.	

Contact Information	
In Americas and Antipodes	<p><b>PHOTRON USA, INC.</b> 9520 Padgett Street, Suite 110 San Diego, CA 92126-4426, USA Phone : 800-585-2129 or 858-684-3555 Fax : 858-684-3558 E-mail : <a href="mailto:image@photron.com">image@photron.com</a> <a href="http://www.photron.com">www.photron.com</a></p>
In Europe, Africa and India	<p><b>PHOTRON EUROPE LIMITED</b> The Barn, Bottom Road, West Wycombe, Buckinghamshire, HP14 4BS, U.K. Phone : +44(0) 1494 48 1011 Fax : +44(0) 1494 48 7011 E-mail : <a href="mailto:image@photron.com">image@photron.com</a> <a href="http://www.photron.com">www.photron.com</a></p>
In other areas	<p><b>PHOTRON LIMITED</b> Fujimi 1-1-8, Chiyoda-Ku Tokyo 102-0071, Japan Phone : +81 3 3238 2107 Fax : +81 3 3238 2109 E-mail : <a href="mailto:image@photron.co.jp">image@photron.co.jp</a> <a href="http://www.photron.co.jp">www.photron.co.jp</a></p>

# *FASTCAM SA8*

Hardware Manual    Revision 1.00E

Publication Date            March, 2013  
Publisher                    PHOTRON LIMITED  
Chiyoda Fujimi Bldg., Fujimi 1-1-8, Chiyoda-ku, Tokyo 102-0071