

FASTCAM SA6
FASTCAM SA6 RV

 **Hardware Manual**

Revision 1.01E

Photron

- The copyright of this manual is held by Photron LIMITED.
- Product specifications and manual contents can change without advanced notification.
- This manual was created taking every possible measure to ensure the accuracy of its contents. However, if you find a section which is unclear, a mistake, or an omission, please contact Photron LIMITED using the contact information provided at the end of the manual.
- Photron LIMITED bears no responsibility for the results of using the product or from following the instructions in this manual.

Introduction

Thank you for your purchase of Photron's high-speed camera system, the "FASTCAM SA6 / SA6 RV" (referred to below as the system).

This manual contains the operating instructions and warnings necessary for using the system.





Before using the system, please read the entire manual.

If any part of this manual is unclear, contact Photron using the contact information printed at the back of the manual.

After you finish reading the manual, store it in a safe place along with the warranty card and refer back to it when necessary.

Manual Notation

The following icons and symbols are used in the explanations in this manual.

Icon/Symbol	Description
	This symbol indicates content that should always be read.
	This symbol indicates instructions that should always be followed when using the software, or things to be careful of when using the software.
	This symbol indicates supplementary items to be aware of when using the hardware.
	This symbol indicates the location of a reference.
	This symbol indicates a space you to use for making notes.
" "	This symbol is used to indicate the names of items on a screen, references, dialog names, and connectors.
[]	This symbol is used to indicate menu names, and sub-menu names.



Using the Manual

This section explains the layout of the manual.

◆ Introduction

The introduction explains the manual and safety precautions.

◆ Chapter. 1 Overview

This chapter gives an overview of the system and an explanation of its features.

◆ Chapter. 2 Setup

This chapter gives an overview of the components that make up the system, and a list of items that should be checked before using the system.

◆ Chapter. 3 Recording

This chapter explains overview of the function for recording.

◆ Chapter. 4 Connecting a PC

This chapter explains the procedure for connecting the system to a PC. Refer to the “Photron FASTCAM Viewer User’s Manual” for additional details on using a PC to control the system.

◆ Chapter. 5 Product Specifications

This chapter explains the system’s specifications.

◆ Chapter. 6 Warranty

This chapter explains about the warranty.

◆ Chapter. 7 Contacting Photron

This chapter lists the contact information to use when contacting Photron if the system malfunctions or if a portion of the manual is unclear.

Using the System Safely and Correctly

In order to prevent injury to yourself and others, and to prevent damage to property, carefully observe the following safety precautions.

Photron has given its full attention to the safety of this system. However, the extent of damage and injury potentially caused by ignoring the content of the safety precautions and using the system incorrectly is explained next. Please pay careful attention to the content of the safety precautions when using the system.



Warning

This symbol indicates actions that carry the risk that a person could receive a serious injury.



Caution

This symbol indicates actions that carry the risk that a person could receive a moderate injury, or that damage to physical property might occur.

- ◆ The safety precautions to be observed are explained with the following symbols.



This symbol indicates actions that require caution.



This symbol indicates actions that are prohibited and must be avoided.



This symbol indicates actions that must always be performed.



Warning



- Do not perform actions that will damage the AC cable or plug.
(Do not damage the cable, modify it, use it near a heater, excessively bend, twist or pull on it, place heavy objects on it, or bundle it.)
Using the cable when damaged can cause fire, electric shock, or a short circuit.



- Do not use the system in a manner which will exceed the rating of the power outlet or wiring equipment used.
Exceeding the power rating might cause a fire from excessive heat.



- Do not insert metallic objects inside, or pour liquids such as water on, the system.
Doing so can cause fire, electric shock, or malfunction from short circuit or heat.



- Do not disassemble or modify the system.
There are high voltages inside the system that can cause electric shock.



- Do not plug in or unplug the power cord with wet hands.
Doing so can cause electric shock.



- Not fully plugging in the power cable can cause fire from electric shock or heat.



- When something is wrong with the system, unplug the power cable immediately.
 - When a foreign substance or liquid, such as metal or water, gets inside.
 - When the outer case is broken or damaged, such as from a fall.
 - When the system produces smoke, a strange smell, or strange sound.Using the system in these conditions might cause a fire or electric shock.



Caution



- Always unplug the system when cleaning it or when it is unused for a long period of time. Leaving or storing the system connected to the power source might cause fire from insulation deterioration or electrical discharge.



- Do not set the system in a location where the temperature gets unusually hot. The trunk and inside of a car can get especially hot in summer. Doing so can cause the outer case and internal components to deteriorate or cause a fire.



- Do not place the system in a location prone to oily smoke or steam, or in a location with a lot of humidity or dust. Oil, moisture, and dust conduct electricity, which can cause a fire or electric shock.



- Ambient temperature 0-40° C, humidity 85% RH or lower, maximum altitude 2000m or lower. In addition, if exceeding these limits, use in a condensation-free environment. Doing so can cause malfunction.



- Do not store the equipment in a location where the temperature goes below -20°C or higher than 60°C. Also, prevent condensation from forming during shipment



- This device is for indoor use, do not use it outdoors. Do not use in a location that has dust. Doing so can cause malfunction.



- When shipping, remove the connecting cable and use the original packaging or a dedicated carrying case. Do not ship the equipment in an environment where the temperature goes below -20°C or higher than 60°C. Also, prevent condensation from forming during shipment



Cleaning of the Image Sensor Surface

Electrostatic Discharge (ESD) events may cause immediate and unrecoverable damage to the image sensor. Please read the following instructions and take **EXTREME CARE** when cleaning the image sensor surface.



- ALWAYS take appropriate anti-static precautions when cleaning or working near the Image sensor.
- DO NOT use any form of cleaning equipment using electrostatic or 'charged fiber' technology.



- Please discharge any electrostatic build up in your body by touching a grounded metallic Surface before working near the camera sensor.
- Very gently, use only clean and dry air to remove dust from surface of the image sensor.
- To remove stubborn contamination use the highest grade (e.g. VLSI grade) pure Isopropyl alcohol (IPA) with optical wipes of 'clean room' grade.
- Extreme care must be taken! Gently wipe across the sensor in a single action.
(DO NOT rub to avoid abrasive damage to delicate optical coatings on the glass surface.)

Table of Contents

Chapter. 1	Overview	1
1.1.	Product Overview and Features	2
Chapter. 2	Setup	3
2.1.	System Components and Accessories	4
2.1.1.	Components	4
2.1.2.	Accessories/Options	4
2.1.3.	Model	5
2.2.	Part Names	6
2.2.1.	Camera Body	6
2.2.2.	Camera Body Part Names	8
2.2.3.	Status Display LEDs on the Rear of the Camera Body	10
2.2.4.	Interchangeable Lens Mounts	12
2.2.5.	LCD Remote Controller (Optional)	13
2.2.6.	RS-422 Serial Control	14
2.2.7.	I/O Port Connector	15
2.2.8.	Power Supply Connector	17
2.3.	Device Connections	18
2.3.1.	Connecting a Video Monitor	18
2.3.2.	Connecting the AC Power Supply	19
2.3.3.	Connecting the LCD Remote Controller (Optional)	20
2.3.4.	Connecting a PC	21
Chapter. 3	Recording	23
3.1.	Image Initialization (Calibration)	24
3.1.1.	Executing Calibration	24
3.1.2.	Saving Calibration Settings	24
3.1.3.	Loading Calibration Settings	24
3.1.4.	Calibration Mode	24
3.1.5.	Mechanical shutter ganged operation (Option)	25
3.2.	Selecting the Frame Rate	25
3.3.	Selecting the Resolution	26
3.3.1.	Resolution Lock	26
3.4.	Selecting the Shutter Speed	27
3.4.1.	Changing SHUTTER MODE	27
3.4.2.	Setting Dual Slope Shutter function	27
3.4.3.	AUTO EXPOSURE Operation	28
3.5.	Selecting the Trigger Mode	30
3.5.1.	START Mode	30
3.5.2.	CENTER Mode	30
3.5.3.	END Mode	31
3.5.4.	MANUAL Mode	31
3.5.5.	RANDOM Mode	31

3.5.6.	RANDOM RESET Mode	32
3.5.7.	RANDOM CENTER Mode	33
3.5.8.	RANDOM MANUAL Mode	34
3.5.9.	TWO STAGE Mode.....	35
3.6.	LOW LIGHT Mode	36
3.7.	VARIABLE Setting	36
3.8.	White Balance Adjustment (Color Models Only).....	37
3.8.1.	Using Preset White Balance (Color Models Only).....	37
3.8.2.	Using User White Balance (Color Models Only).....	37
3.9.	Color Enhancement Function (Color Models Only)	38
3.10.	LUT (Look-Up Table) Operations	38
3.10.1.	Using a Custom LUT.....	42
3.11.	Edge Enhancement Function	42
3.12.	Black Adjust Level.....	42
3.13.	Partition Memory & Record.....	43
3.14.	Input/Output Signal Types.....	44
3.14.1.	TRIG TTL IN Connector	44
3.14.2.	TRIG TTL OUT Connector	44
3.14.3.	TRIG SW IN Connector	44
3.14.4.	SYNC IN Connector	44
3.14.5.	GENERAL IN Connector.....	45
3.14.6.	GENERAL OUT (1,2,3) Connector	45
3.15.	Using External Triggers.....	46
3.15.1.	Inputting an External Trigger Signal.....	46
3.15.2.	Outputting External Trigger Signals	48
3.16.	Using External Synchronization Signals.....	49
3.16.1.	Inputting an External Synchronization Signal	49
3.16.2.	Outputting an External Synchronization Signal	49
3.16.3.	Synchronizing Multiple FASTCAM SA6 Systems	50
(Multiple Unit Synchronized Recording).....		50
3.16.4.	Synchronizing the System with Other External Devices.....	52
(Frame Rate Synchronized Recording).....		52
3.16.5.	Synchronizing the System with Other Cameras	54
(Mixed Device Synchronized Recording)		54
3.17.	GENERAL Signal Settings.....	55
3.17.1.	GENERAL IN Signal Settings	55
3.17.2.	GENERAL OUT Signal Settings	56
3.18.	Signal Delay	57
3.19.	Event Marker Function.....	58
3.20.	Using USER SW (Programmable Switch).....	59
3.21.	Using MCDL (Analog Waveform Synchronized Recording Unit).....	60
3.22.	IRIG Time Code (External Time Synchronization).....	61

Chapter. 4 Connecting a PC

63

4.1.	Connecting the Gigabit Ethernet Interface to a PC	64
4.1.1.	Connecting the System and a PC.....	65

4.1.2.	Setting the IP Address	65
4.1.3.	Using DHCP (Dynamic Host Configuration Protocol).....	65
4.1.4.	Connecting Multiple Systems and a PC	66
4.1.5.	Gigabit Ethernet Interface Initialization	66

Chapter. 5 Product Specifications 67

5.1.	Specifications	68
5.1.1.	Product Specifications.....	68
5.1.2.	General Specifications	69
5.1.3.	Options.....	70
5.1.4.	Frame Rate and Resolution	72
5.1.5.	Recordable Image Count/Resolution	74
5.1.6.	Shutter Speed List.....	75
5.1.7.	List of Frame Rates Selectable with the VARIABLE Setting.....	77
5.2.	Dimensions	78
5.2.1.	Camera Body	78
5.2.2.	LCD Remote Controller (Optional).....	80
5.2.3.	AC Power Supply Adapter	83
5.3.	Cleaning the Filter.....	84

Chapter. 6 Warranty 85

6.1.	About the Warranty	86
------	--------------------------	----

Chapter. 7 Contacting Photron 87

7.1.	Contact Information.....	88
------	--------------------------	----



Chapter. 1 **Overview**

1.1.Product Overview and Features

1.1. Product Overview and Features

The FASTCAM SA6 / SA6 RV is a powerful engineering tool for use in research and development, design, production, and quality control, and in numerous fields such as science, medicine, biology, aviation and space.

As for recording performance, the system can record at a maximum resolution of 1,920x1,440 pixels, 1,125 fps at the full frame resolution, and 1,500 fps at the full high definition resolution of 1,920x1,080 pixels. With this system you can capture various high speed phenomena at unprecedented high resolution video. Not only high resolution video, the camera also features outstanding recording performance in the high speed range with a maximum frame rate of 75,000 fps.

Since the camera can be operated in two ways, via the LCD remote controller (optional) or by using the PC software over a Gigabit Ethernet connection, it can be operated in the desired manner depending on the conditions and the scene.

The system combines both recording performance and operability, to produce a high speed camera that is easy to use by anyone. Use the state-of-the-art technology in the FASTCAM SA6 to slow down and observe high-speed phenomena, and also as an input component for a dynamic image measurement system. The procedures for operating the system are explained in this manual.



FASTCAM SA6



FASTCAM SA6 RV

Chapter. 2 **Setup**

2.1. System Components and Accessories

2.2. Part Names

2.3. Device Connections

2.1. System Components and Accessories

2.1.1. Components

The system's standard components are listed below. Remove the components from the packaging and check the system.

1.	Camera Body	One
2.	AC Power Supply Unit/AC Cable	One
3.	C Mount Adapter	One
4.	Hexagonal Lens Mount Adapter Wrench (1.5 mm, 2 mm, 3 mm) 4 each	One
5.	Lens Mount Cap (Body Integrated)	One
6.	I/O Cable	One
7.	FASTCAM Series Setup Disk (Driver/Application CD)	One
8.	FASTCAM SA6 / SA6 RV Hardware Manual (This Manual)	One
9.	Photron FASTCAM Viewer User's Manual	One
10.	Making a Gigabit Ethernet Connection (Simple Procedure Manual)	One
11.	Gigabit Ethernet Interface Cable (LAN Cable)	One

2.1.2. Accessories/Options

The following options are available for the system.

1. LCD Remote Controller
2. PL Mount Kit
3. B4 Mount Kit
4. 4 Output Trigger Box
5. MCDL (Analog Waveform Synchronized Recording Unit)
6. Dedicated Carrying Case
7. LCD Monitor Mounting Hardware
8. Accessory Mounting Hardware
9. Spare Power Supply Connector (For Custom Cable Creation)
10. LAN Connector Dust-Proof Cover
11. IDX Battery Cable
12. Lens Mount with Filter Changer (Triple Type / Single Type)
13. Mechanical shutter (F mount and C mount)

2.1.3. Model

The system's models are split according to color/monochrome, and there are a total of six models according to the amount of memory.

The models are listed below.

Max. Frame Rate	Sensor Type	Memory	Model Name
75,000FPS	Color	8GB	FASTCAM SA6 75K-C1
		16GB	FASTCAM SA6 75K-C2
		32GB	FASTCAM SA6 75K-C3
	Monochrome	8GB	FASTCAM SA6 75K-M1
		16GB	FASTCAM SA6 75K-M2
		32GB	FASTCAM SA6 75K-M3

Supplement

- "RV (Range Version) type" is prepared for each model.

It has be sealed-up a camera chassis for keep it free of dust.

2.2. Part Names

The system is composed of components including the camera body, AC power supply, and the "Photron FASTCAM Viewer" controls software (referred to below as PFV).



For each of the system components.

- Do not expose to shock outside of specifications.
- Do not use in an area with flammable gas or dust present.
- Do not place in an unstable location such as on a wobbly platform or an incline.
- Do not disassemble or modify.
- Do not expose to liquids such as water.
- Do not use in a manner where excessive force is applied.

2.2.1. Camera Body

The system has monochrome and color models, and for each of those models there are three types: standard 8GB of memory and 16GB and 32GB large capacity types. You can select from these models according to the desired application when purchasing.

The camera body contains IC memory for recording images and has been designed with the capability to save high-speed images as uncompressed digital data. The camera body has HD SDI/video output connectors that can playback recorded images on a video monitor, a Gigabit Ethernet interface to connect to a PC to fully control the camera or download data, various I/O (input/output) connectors for external synchronization/trigger signals, and an interface to record IRIG/GPS time code/MCDL analog waveform.



Apperance



Rear

FASTCAM SA6



Apperance



Rear

FASTCAM SA6 RV

2.2.2. Camera Body Part Names

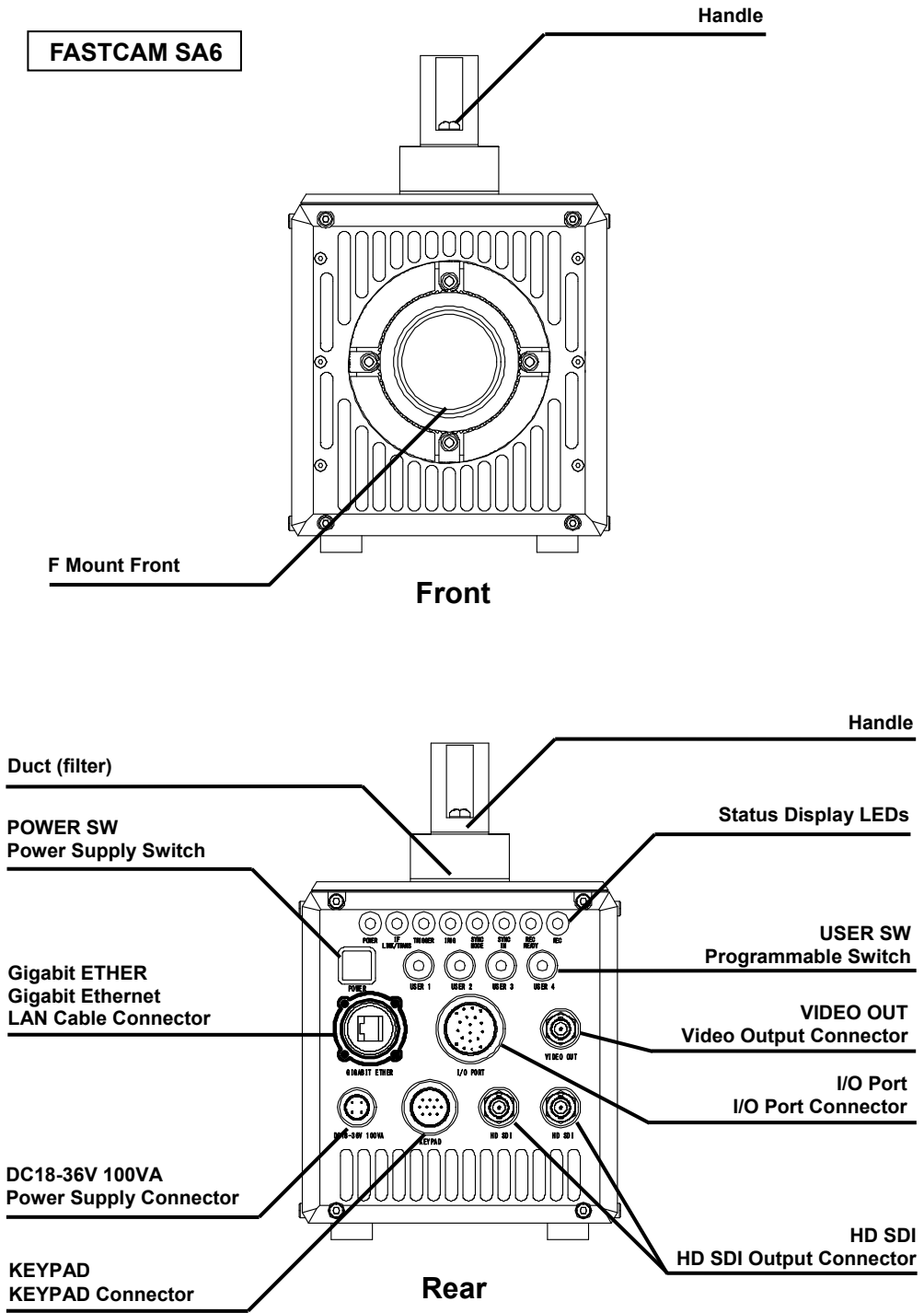

FASTCAM SA6 RV

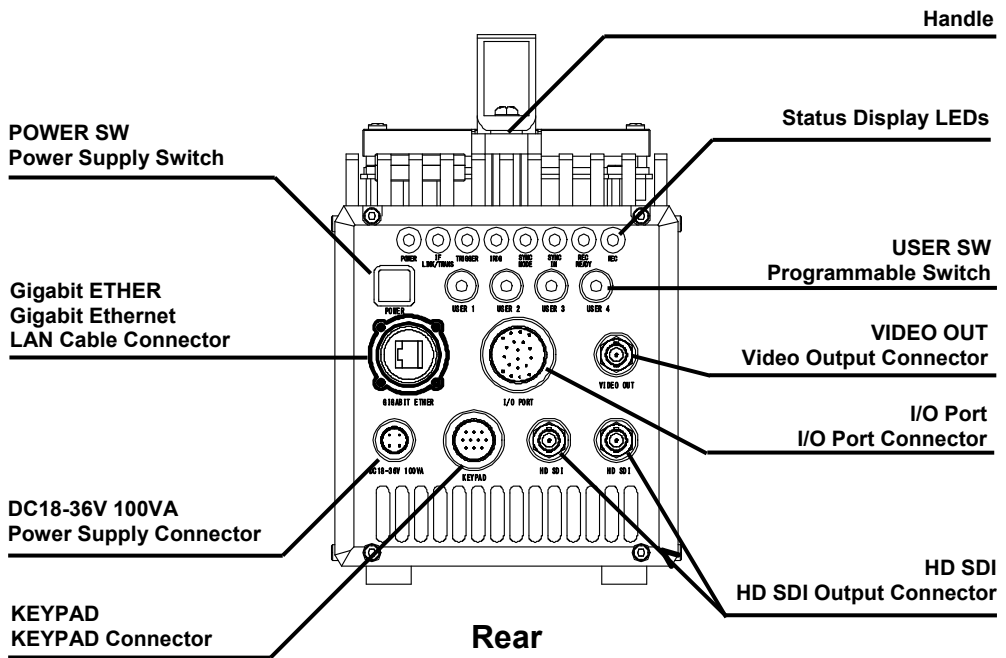
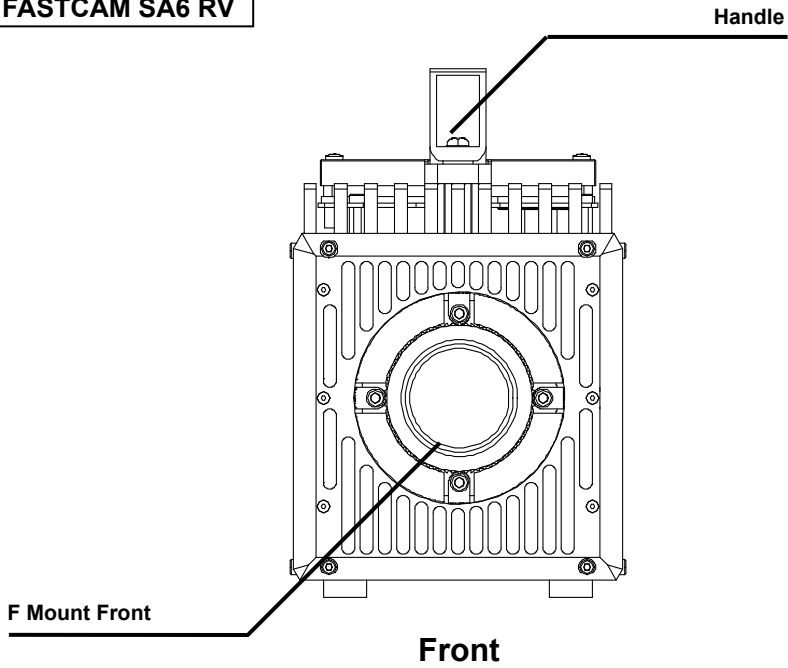

2.2.3. Status Display LEDs on the Rear of the Camera Body

There are a number of LEDs on the rear of the system's camera body. These LEDs indicate the status of the system. The meaning of each LED is explained here.



- **POWER (Green)**
LED ON: Power On
LED OFF: Power Off

- **IF LINK/TRANS (Red)**
LED ON: The Gigabit Ethernet interface is connected
LED FLASHING: Data is transferring
LED OFF: The Gigabit Ethernet interface is not connected

- **TRIGGER (Yellow)**
LED ON: A trigger signal has been input (illuminates for 0.1 s when the trigger signal is input)
LED OFF: A trigger signal has not been input

- **IRIG (Green)**
LED ON: An IRIG/GPS signal is being input
LED OFF: An IRIG/GPS signal is not being input

- **SYNC MODE (Red)**
LED ON: In external synchronization mode
LED OFF: In internal synchronization mode

- **SYNC IN (Yellow)**
LED ON: A synchronization signal is being input
LED OFF: A synchronization signal is not being input

- **REC READY (Yellow)**
LED ON: Ready to record
LED FLASHING: ENDLESS recording
LED OFF: Not ready to record

- **REC (Red)**
LED ON: Random mode ready state
LED FLASHING: Ready to record
LED OFF: Not ready to record

◆ Illumination/blinking in operational states

- During low light mode operation LEDs other than POWER (green) and IF LINK/TRANS (red) blink at a regular interval.
- When calibration is run from USER SW or the LCD remote controller LEDs other than POWER (green) and IF LINK/TRANS (red) blink alternately from right to left three times and from left to right three times.
- During the Gigabit Ethernet interface initialization LEDs other than POWER (green) and IF LINK/TRANS (red) blink alternately from right to left and from left to right a number of times.

 Reference

- For how to initialize of the Gigabit Ethernet interface, refer to "4.1.5. Gigabit Ethernet Interface Initialization", page 66.

2.2.4. Interchangeable Lens Mounts

The lens mount on the system can be changed according to the recording application.

There are five types of interchangeable lens mounts: "Nikon F Mount", "C Mount", "PL Mount" (optional), "B4 Mount" (optional), and "Lens Mount with Filter Changer(Triple Type / Single Type)" (optional).

Moreover, for a [Nikon F Mount] or a [C Mount], an optional equipment of Mechanical shutter can be selected.

◆ How to change lens mounts (Nikon F Mount → C Mount)

1. Remove the four M5 hexagonal socket bolts with the hexagonal wrench.
2. Remove the Nikon F mount portion as a whole unit.
3. Attach the C mount unit with the hexagonal socket bolts.
4. After attaching the unit, always check to make sure it is not loose or rattles.

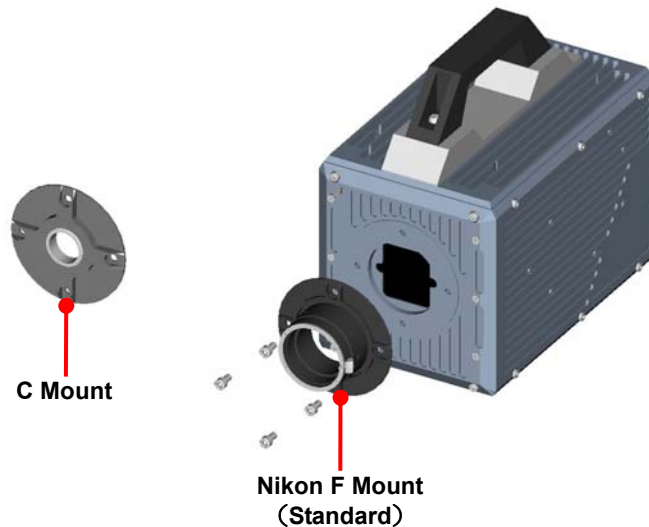

! Caution

- When using the C mount or B4 mount, clipping may occur around the edge of the video.
- When a mechanical optional shutter is selected, only F mount and C mount can be exchanged.

2.2.6. RS-422 Serial Control

The system supports operation with serial control via an RS-422 connection through the "KEYPAD" connector.

By setting the [STATUS OUT] menu to ON, the system status can be output via the serial connection.

For details, check the command list.

Serial control commands are available as separate list of commands. Please contact Photron or the dealer where the system was purchased regarding the command list.

A cable is not offered as an accessory. When using RS-422 control, construct a cable using the pin diagram below for reference.

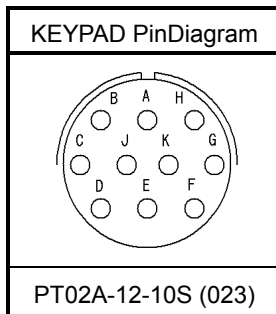

Connector Name	Signal Name	Pin No.	Camera Body onnector Model Name (Manufacturer)	Cable Connector Model Name (Manufacturer)	Input Connector
KEYPAD	+12V OUT	A	PT02A-12-10S (023) (Amphenol)	PT06A-12-10P (023) (Amphenol)	Not Specified
	SIGNAL GND	B			
	RXD+	C			
	RXD-	D			
	TRIGGER SW	E			
	TXD-	F			
	TXD+	G			
	POWER GND	H			
	VBS GND	J			
	VBS	K			



When using the connector pins directly, refer to the chart above and ensure the wiring is correct. Incorrect wiring can cause malfunction.



The voltage on pin A (+12V OUT) is used to power the LCD remote controller, do not use it for other purposes.

Reference

- For inquires related to our product, refer to "7.1. Contact Information", page 88.

2.2.7. I/O Port Connector

By inputting an external trigger or synchronization signal and by outputting exposure timing or synchronization signal, these signals can be used as a part of the system. The input/output signal connectors on the system have been bundled into a single connector, the "I/O port" connector, and it is possible to connect to and access each type of signal by using the specialized multi-connector.



A signal other than the specified signal must not be input to the various connectors.

Use extreme caution as there is a risk of damage to both devices, the input device and the output device.

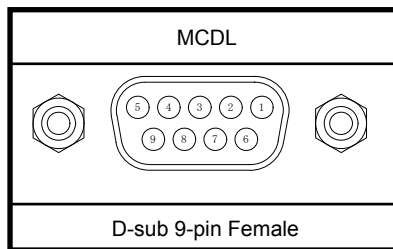
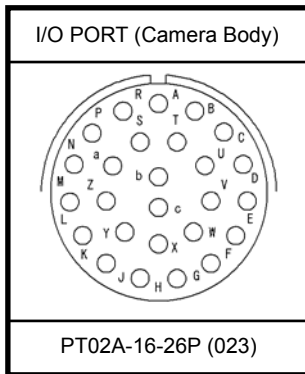
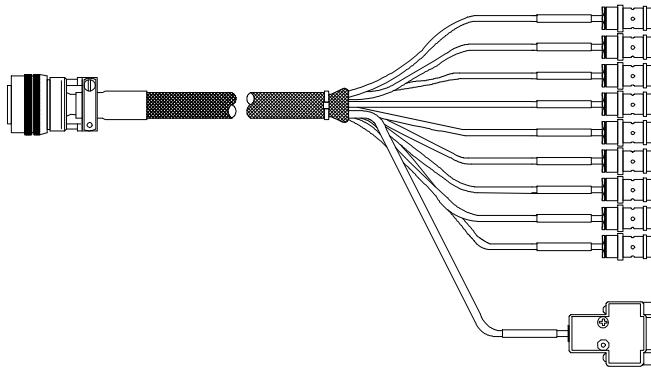

Reference

- For the signal which can be inputted, refer to "3.14. Input/Output Signal Types", page 44.

Conector Name	Signal Name	Pin No.	Camera body Conector model No. (Manufacturer)	Cable connector model No. (Manufacturer)	Input conector (Pin No.)
I/O PORT	TRIGGER TTL IN	A	PT02A-16-26P (023) (Amphenol)	PT02A-16-26S (424) (Amphenol)	BNC
	TRIGGER TTL OUT	B			BNC
	TRIGGER SW	C			BNC
	SYNC IN	D			BNC
	GENERAL IN	E			BNC
	GENERAL OUT1	F			BNC
	GENERAL OUT2	G			BNC
	MCDL CLK-	H			D-sub 9 pin (5)
	MCDL CLK+	J			D-sub 9 pin (4)
	MCDL SYNC-	K			D-sub 9 pin (1)
	MCDL SYNC+	L			D-sub 9 pin (2)
	MCDL DATA_B-	M			D-sub 9 pin (6)
	MCDL DATA_B+	N			D-sub 9 pin (9)
	MCDL DATA_A-	P			D-sub 9 pin (7)
	MCDL DATA_A+	R			D-sub 9 pin (8)
	POWER GND	S			-
	GENERAL OUT3	T			BNC
	SIGNAL GND	U			BNC
	SIGNAL GND	V			-
	N.C.	W			-
	SIGNAL GND	X			-
+18 - +V36	Y	-			
+18 - +V36	Z	-			
+18 - +V36	a	-			
IRIG	b	BNC			
IRIG GND	c	BNC			

 **Supplement**

- Pin U's SIGNAL GND signal is the common ground for BNC.

2.2.8. Power Supply Connector

This connector is used to input the DC power supply. Connect the supplied AC adapter or the optional IDX battery cable (battery sold separately).

A cable connector is available as an option. When using other power supplies, construct a cable using the pin diagram below for reference.

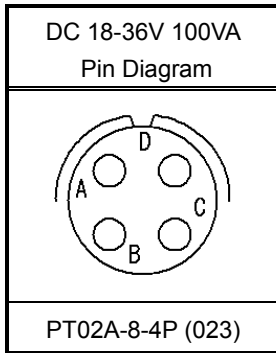

Connector Name	Signal Name	Pin No.	Camera body connector model name (Manufacturer)	Cable connector model name (Manufacturer)
DC18-36V 100VA	+18V~+36V IN	A	PT02A-8-4P (023) (Amphenol)	PT06A-8-4S (424) (Amphenol)
	POWER GND	B		
	POWER GND	C		
	+18V~+36V IN	D		



Warning

When using the connector pins directly, refer to the chart above and ensure the wiring is correct.

If the wiring is incorrect, not only is there the danger of the system malfunctioning, but also of fire and electric shock.



Warning

Do not use a power supply which does not meet the system's specifications, or a power supply you cannot guarantee the safety of.

By using a power supply outside of the system specifications, not only is there the danger of the system malfunctioning, but also of fire and electric shock.

2.3. Device Connections

2.3.1. Connecting a Video Monitor

A video monitor connected to the camera controller can be used to check the live image (Camera Pass - through image). Connect the video input connector according to the video signal type of the monitor to display to the "VIDEO OUT" connector or "HD SDI" OUT connector on the rear of the camera body with a BNC cable. Which connector video is output from can be set with the "LCD remote controller (optional)" or with PFV.

HD SDI's support formats are listed in the chart below.

NTSC setting	1080i	60Hz , 59.94Hz
	1080p	30Hz , 29.97Hz , 24Hz , 23.98Hz , 24Hz(sF) , 23.98Hz(sF)
PAL setting	1080i	50Hz
	1080p	25Hz , 24Hz , 23.98Hz , 24Hz(sF) , 23.98Hz(sF)

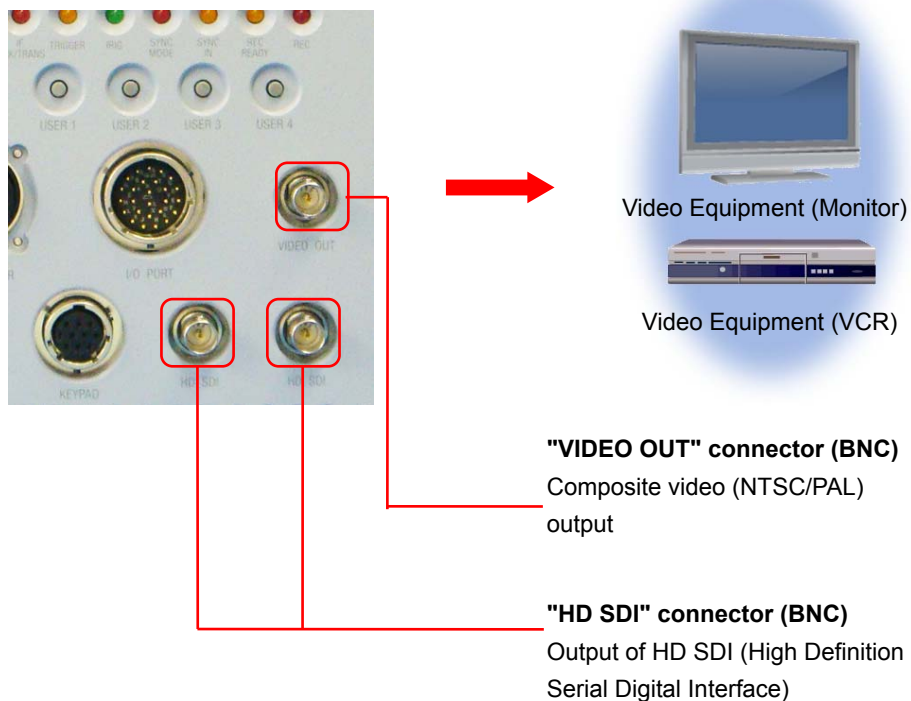

Supplement

- Since the output of composite video/HD SDI is exclusive, color bars are displayed on the output not selected. (Color bars are a reference guide).
- Use 5C-FB specification cables for HD SDI output.

2.3.2. Connecting the AC Power Supply

Connect the supplied AC power supply unit to the power supply.



1. Connect the AC power supply unit to the "DC18-36V 100VA" connector on the rear of the camera body.
2. Connect the AC cable to the AC power supply unit.
3. Connect the AC cable to the power outlet.

Reference

- For the specification of the power supply which can be used, refer to "5.1.2. General Specifications", page 69.

2.3.3. Connecting the LCD Remote Controller (Optional)

If you have the optional LCD remote controller, connect it by plugging the LCD remote controller connector into the connector labeled "KEYPAD" on the rear of the camera body.

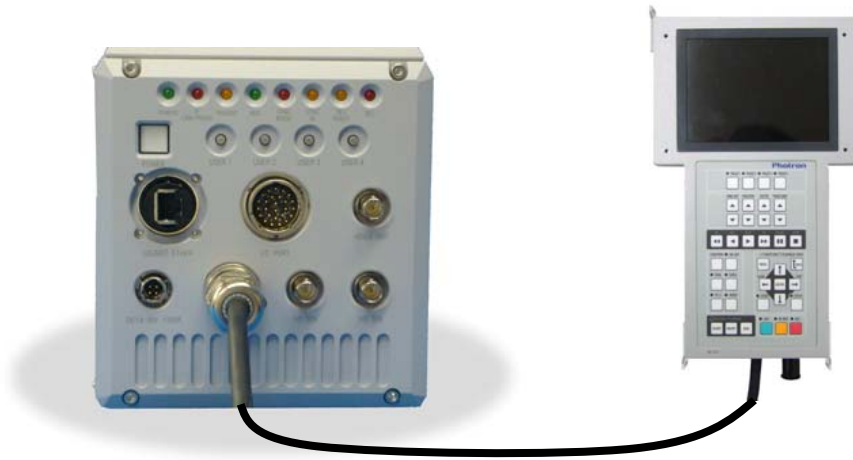

Supplement

- The LCD remote controller is hot-pluggable. It can be plugged in and removed while the system's power is on.

Reference

- For how to operate of the LCD Remote Controller, refer to "LCD Remote Controller User's Manual".

2.3.4. Connecting a PC

The system can be operated remotely from a PC using the Gigabit Ethernet interface. This section explains the required setup when connecting the system to a PC.



To connect a PC to the system, connect the system to a commercially available 1000BASE-T (Gigabit Ethernet) compatible interface board with the LAN cable provided. For the LAN cable, prepare a UTP or STP CAT5E (enhanced category 5 or higher LAN cable. (UTP: unshielded, STP: shielded)

The maximum cable length between the PC and the system is, compliant to the 1000BASE-T specification, up to 100 m. One PC can connect to a maximum of 64 Photron Gigabit Ethernet interface equipped cameras using a hub. When connecting multiple devices, connect through a switching hub that can connect at 1000BASE-T. The maximum length of the cable that connects the system (or PC) to the switching hub is also 100 m.

Reference

- For operating instructions of Photron FASTCAM Viewer software, refer to "Photron FASTCAM Viewer User's Manual".



Chapter. 3 Recording

- 3.1. Image Initialization (Calibration)**
- 3.2. Selecting the Frame Rate**
- 3.3. Selecting the Resolution**
- 3.4. Selecting the Shutter Speed**
- 3.5. Selecting the Trigger Mode**
- 3.6. LOW LIGHT Mode**
- 3.7. VARIABLE Setting**
- 3.8. White Balance Adjustment (Color Models Only)**
- 3.9. Color Enhancement Function (Color Models Only)**
- 3.10. LUT (Look-Up Table) Operations**
- 3.11. Edge Enhancement Function**
- 3.12. Black Adjust Level**
- 3.13. Partition Memory & Record**
- 3.14. Input/Output Signal Types**
- 3.15. Using External Triggers**
- 3.16. Using External Synchronization Signals**
- 3.17. GENERAL Signal Settings**
- 3.18. Signal Delay**
- 3.19. Event Marker Function**
- 3.20. Using USER SW (Programmable Switch)**
- 3.21. Using MCDL (Analog Waveform Synchronized Recording Unit)**
- 3.22. IRIG Time Code (External Time Synchronization)**

3.1. Image Initialization (Calibration)

In order to maximize the high image quality of the system, it is necessary to correct the non-uniformity in each pixel that is inherent in the image sensor.

For this product, an output correction of each pixel on the image sensor is adopted. Therefore, a faithful image output can be obtained corresponding to the light input.

Important

- In order to obtain faithful image output, execute calibration when the following settings are changed.
 - When the frame rate is changed
 - When the shutter speed is changed
 - When the resolution is changedAlso, depending on the settings, phenomena such as the following may occur.
 - Fixed noise, horizontal bands appear
 - A portion of the screen is clear, but noise appears in the area around itThese phenomena can be resolved by executing calibration again.

3.1.1. Executing Calibration

Calibration is executed from the "LCD remote controller (optional)" or from PFV.

Reference

- For the procedure of performing this function, refer to "LCD Remote Controller User's Manual" or "Photron FASTCAM Viewer User's Manual".

3.1.2. Saving Calibration Settings

The black image data for correction use that was obtained by executing the calibration can be saved internally on the system.

3.1.3. Loading Calibration Settings

Saved black image data for correction can be loaded.

3.1.4. Calibration Mode

For this product, the calibration method can be changed by user. A NORMAL method and a FINE method can be used.

3.1.5. Mechanical shutter ganged operation (Option)

When using the optional Mechanical shutter, it is no need to shade the light since the shutter will close automatically when carrying out a calibration.

3.2. Selecting the Frame Rate

With the system, you can record images from 60 (50) to 1,125 fps using the full 1,920x1,440 pixel resolution of the image sensor. For frame rates faster than 1,125 fps, high-speed photography is achieved by limiting the read area of the image sensor.

Supplement

- The minimum frame rate in NTSC mode is 60 fps.
- The minimum frame rate in PAL mode is 50 fps.

Reference

- For frame rates faster than 1,125 fps, the resolution is automatically set to the maximum available at that frame rate. For more details, refer to “5.1.4. Frame Rate and Resolution”, page 72.

3.3. Selecting the Resolution

With the system, you can record images with a maximum size of 2,764,800 pixels using the high-speed image sensor, which has a maximum size of 1,920x1,440 pixels. You can also record at even faster frame rates or reduce the amount of image data to make even longer recordings by limiting the resolution according to the application.

Reference

- For more information of relation between Frame Rate and Resolution, refer to “5.1.4. Frame Rate and Resolution”, page 72.

3.3.1. Resolution Lock

Generally, a max resolution under respective FPS will be set automatically when the FPS is changed. Under the circumstance of using a Resolution Lock function, the speed can be changed while resolution is fixed to a certain value.

Caution

- When using a Resolution Lock function, if a resolution that does not compatible with the specified FPS is selected, a max resolution under the specified speed will be set automatically instead.

3.4. Selecting the Shutter Speed

The shutter speed is independent of the frame rate, and you can control the exposure time in one frame using the electric shutter. By making an exposure that is of a shorter period than the frame rate, high-speed objects can be photographed blur-free.

The shutter speed can be set from 1/frame s to a maximum of 1/3,670,000 s (approximately 2.76 μ s).

Caution

- The numerical value of [0.xxx S] display serves as actual exposure time.
- The numerical value of [1/xxx S] display is round figure. It differs from actual exposure time a little.

Reference

- For more information of Shutter Speed, refer to “5.1.6. Shutter Speed List”, page 75.

3.4.1. Changing SHUTTER MODE

By switching between [MODE1] and [MODE2] on the [SHUTTER MODE] submenu on the [SHUTTER] menu, the shutter speed value first used when the frame rate is changed can be set.

MODE1: Changing the frame rate automatically sets the shutter speed to 1/frame s.

MODE2: Changing the frame rate does not change the shutter speed, it maintains the current setting.

3.4.2. Setting Dual Slope Shutter function

DS SHUTTER is a mode that records the high brightness portion and low brightness portion in one image at the same time by adjusting the light exposure internally in the sensor. By using this function, when recording a subject with an extremely large difference in the brightness in the image, the sensor functions so that it can record at the proper light exposure for both the high brightness and low brightness portions.

Caution

- This function cannot be used with the operations below.
 - When the AUTO EXPOSURE function is used
 - When the trigger mode is RANDOM RESET
- When using the DS SHUTTER function on a color model, there are situations where the colors become unbalanced and the color reproducibility degrades.

The light exposure adjustment can be set from 0% to 95% in 5% increments according to the subject to be recorded.

Supplement

- The amount of adjustment is expressed as %.For the strength of the adjustment, 0% is no adjustment, 95% is the maximum effect.

3.4.3. AUTO EXPOSURE Operation

The system has a function that automatically varies the shutter (the sensor's exposure time) for the quantity of light input so that it will achieve the desired image output level.

After the settings are made once, this function displays its effect when recording in an environment where the subject's amount of light changes.

When using this function the following four items must be set in advance.

"AREA", "TARGET VALUE", "RANGE", "SHUTTER"

Each of these settings is explained below.

◆ **AREA**

Sets the image area.

The auto exposure function operates so that the average value of the image output level in the area specified here becomes the desired image output level.

◆ **TARGET VALUE**

Sets the desired image output level. Set this value as a 10-bit gradation (0-1,023).

◆ **RANGE**

Gives the desired image output level a range. Set this value as a 10-bit gradation (0-1,023).

The auto exposure function operates so that the average value of the image output level in the area specified here becomes the desired image output level.

◆ **SHUTTER**

Sets the maximum exposure time. Set in order to prevent subject blur from an exposure time that is too long.



Important

- The Auto Exposure function keeps a constant image brightness by varying the shutter speed (sensor's exposure time).

Therefore, the image may deteriorate as the shutter speed varies from the calibrated setting while using this function.

Please refer to "3.1. Image Initialization (Calibration) ", page 24 for details.



Important

- When the auto exposure function is operating, the camera will not perform a shutter operation with an exposure time longer than the shutter value set here.

These settings are shown in the diagram below.

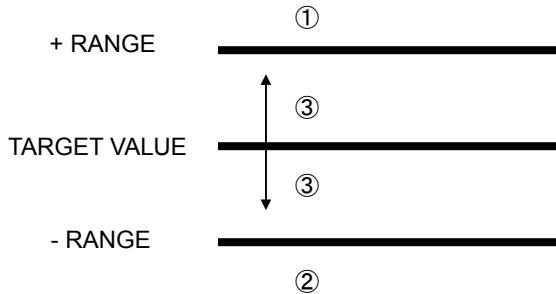

If the image level being output (the average value of the area set with AREA) is □, □, or □, the function operates as below.

- ◆ For position □

Since the image level being output is higher than the range $TARGET\ VALUE \pm RANGE$, the function operates to close the shutter (shorten the exposure time).

- ◆ For position □

Since the image level being output is lower than the range $TARGET\ VALUE \pm RANGE$, the function operates to open the shutter (lengthen the exposure time).

- ◆ For position □

Since the image level being output is within the range of $TARGET\ VALUE \pm RANGE$, the operation of the shutter is not varied.

- The DS SHUTTER function is inactive while the AUTO EXPOSURE function is being used.
- When the RANGE setting is a small value, the range of the desired image output level narrows.
- If the RANGE value is made smaller than necessary, the image level is difficult to place in the desired □ position.

In this case, the variable shutter operation cannot place the image level in the desired □ position and a phenomenon occurs where the image output level is unstable.

When a situation like this occurs, it can be resolved by making RANGE a larger value.

3.5. Selecting the Trigger Mode

With the system, in order to reliably capture high-speed phenomena, many kinds of trigger modes have been made available. These trigger modes are explained next.

There are five types of trigger modes which are listed below.

- START
- MANUAL
- RANDOM CENTER
- CENTER
- RANDOM
- RANDOM MANUAL
- END
- RANDOM RESET
- TWO STAGES

3.5.1. START Mode

START mode is a trigger mode where recording starts the instant the trigger is input, the scene is recorded until the memory is full, and then recording ends. This mode is suitable for taking images of high-speed phenomena when what will happen, and when it happens, is known in advance. For example, in a situation with a maximum useable memory of two seconds of recording, two seconds of high-speed video is saved immediately after the trigger is input.



3.5.2. CENTER Mode

CENTER mode is a trigger mode where an equal amount of content recorded before and after the trigger is input is saved to memory. This mode is suitable for viewing before and after an important instant. For example, in a situation with a maximum useable memory for two seconds of recording, one second before and one second after the trigger was input is recorded for a total of two seconds of high-speed video.

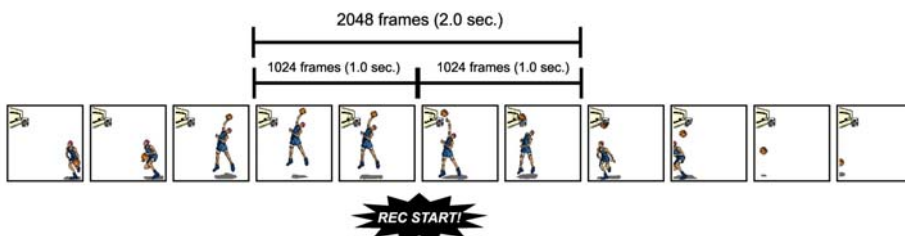

3.5.3. END Mode

END mode is a trigger mode where the content recorded immediately before the trigger is input is saved to memory. This mode is suitable for recording a high-speed phenomenon where it is hard to predict when the important action will start and stop. For example, in a situation with a maximum useable memory for two seconds of recording, the two seconds of high-speed video immediately before when the trigger was input are saved.



3.5.4. MANUAL Mode

MANUAL mode is a trigger mode, similar to CENTER mode, where the content recorded before and after the trigger is input is saved to memory, but the proportion of time before and after the trigger can be set as required. For example, in a situation with a maximum record time of two seconds, 0.5 seconds before and 1.5 seconds after the trigger is input are recorded and saved, a total of two seconds of high-speed video.

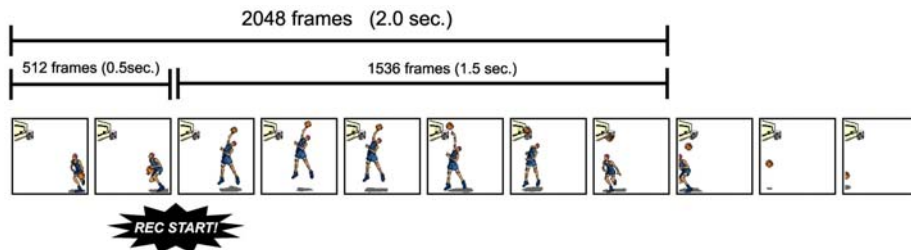

3.5.5. RANDOM Mode

RANDOM mode is a trigger mode where each time a trigger is input only a predetermined number of frames are saved to memory. For example, this function is convenient for a subject which is an irregular and repeated phenomenon which can have a trigger output produced for each cycle or occurrence. The number of frames recorded each time the trigger is input can be set as desired, in one frame increments, from one frame to the maximum of all the recordable frames available.

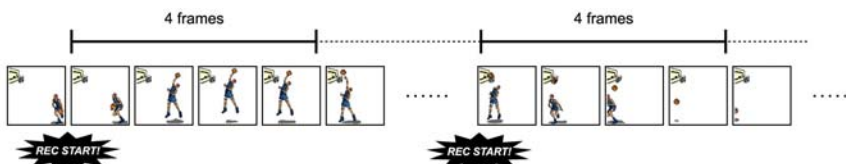

3.5.6. RANDOM RESET Mode

RANDOM RESET mode is explained here by comparing its operation with the normal mode. RANDOM RESET mode is a mode to improve the temporal accuracy of the record start timing and the timing of the trigger input, where, to put it simply, with the input of the trigger signal, at the timing that it is input, the camera's record timing is reset.

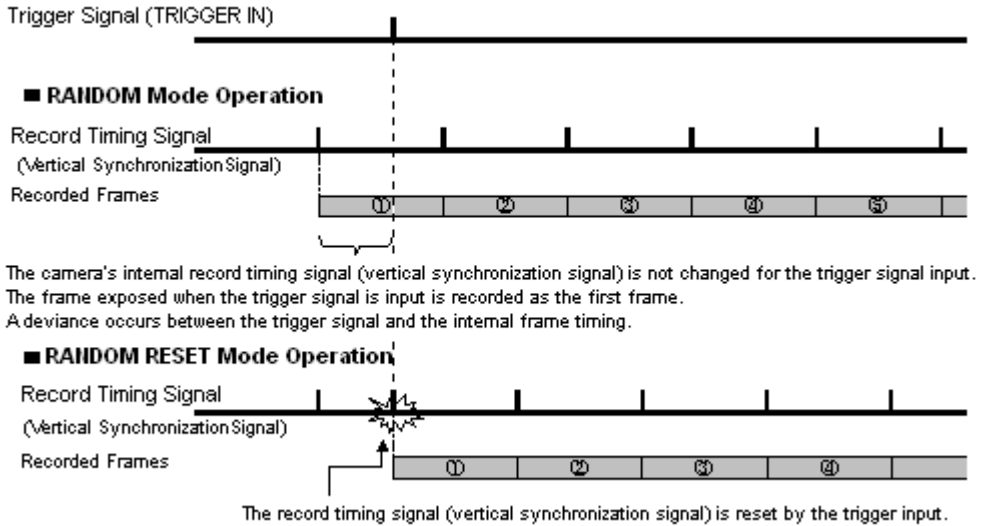

When the camera is set to the normal RANDOM mode (the same as START mode) and RANDOM RESET mode, the difference in the recording operation for the trigger input is shown graphically. In the normal RANDOM mode and START mode, the camera starts recording when the trigger is input, but the internal record timing signal is independent and it operates regardless of when the trigger is input. For this reason, there may be situations where the start time of the first frame when the trigger is input is advanced almost a full frame. The range of this overlap also cannot be known. On the other hand, in RANDOM RESET mode, the camera's internal record timing signal is reset by the trigger input and exposure starts anew. For this reason, the trigger input time and the timing of the start point of the first frame are constant. The interval from when the trigger is input until the exposure begins is approximately 0.7 μ s.

3.5.7. RANDOM CENTER Mode

RANDOM CENTER mode is a trigger mode, similar to RANDOM mode, where each time a trigger is input only a predetermined number of frames are saved to memory. The difference between this mode and RANDOM mode is that in RANDOM mode the number of specified frames are recorded directly after the trigger signal, whereas in RANDOM CENTER mode, at the timing of the trigger signal, the frames before and after the trigger remain in the recording memory. For example, this function is convenient for a subject which is an irregular and repeated phenomenon which can have a trigger output produced for each cycle or occurrence, and you want to check the action before and after the trigger timing. The number of frames recorded each time the trigger is input can be set as desired, in one frame increments, from one frame to the maximum of all the recordable frames available.

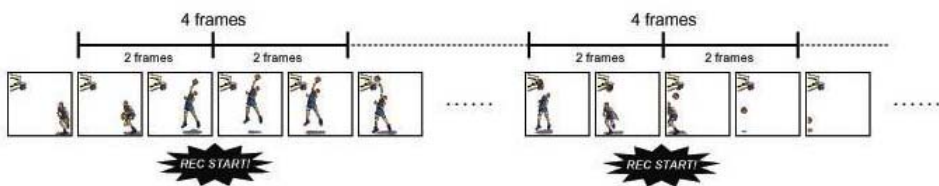

◆ Setting the RANDOM CENTER mode frame count

Setting the frame count in RANDOM CENTER mode is the same as setting the frame count for RANDOM mode.

Reference

- For how to setup of RANDOM Mode, refer to “3.5.5. RANDOM Mode”, page 31.

◆ Setting the RANDOM CENTER mode record count

The number of trigger inputs that can be accepted in RANDOM CENTER mode is a maximum of 10. Set the number of trigger inputs in advance, and the recording operation can be ended when that amount of trigger inputs is finished.

3.5.8. RANDOM MANUAL Mode

RANDOM MANUAL mode is a trigger mode, similar to RANDOM mode, where each time a trigger is input only a predetermined number of frames are saved to memory. The difference between this mode and RANDOM mode is that in RANDOM mode the number of specified frames are recorded directly after the trigger input, whereas in RANDOM MANUAL mode, at the timing of the trigger input, the frames before and after the trigger, each specified as desired, remain in the recording memory. For example, this function is convenient for a subject which is an irregular and repeated phenomenon which can have a trigger output produced for each cycle or occurrence, and you want to check the action before and after the trigger timing. The number of frames recorded each time the trigger is input can be set as desired, in one frame increments, from one frame to the maximum of all the recordable frames available.

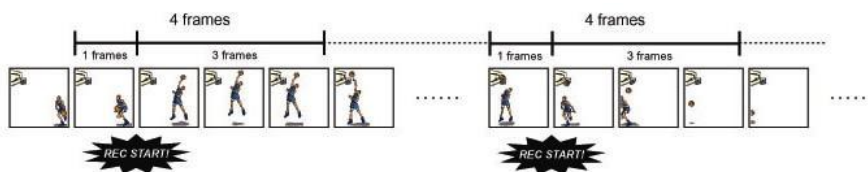

◆ Setting the RANDOM MANUAL mode record count

Setting the record count in RANDOM MANUAL mode is the same as setting the record count for RANDOM CENTER mode.

Reference

- For how to setup of RANDOM Mode, refer to “3.5.5. RANDOM Mode”, page 31.

◆ Setting the RANDOM MANUAL mode frame count

To use RANDOM MANUAL mode, the proportion of frames to record before and after the trigger must be set in advance before recording.

3.6. LOW LIGHT Mode

The more you increase the frame rate or shutter speed of the camera, the less light enters the camera making the displayed image darker. Low light mode is a function that temporarily increases the exposure time, making the displayed image easier to see to enable you to focus and setup the camera.

Putting the camera in to the RECORD mode will immediately return the camera to the original frame rate and shutter settings selected.

3.7. VARIABLE Setting

In the recording conditions settings, the frame rate and resolution can be set to the desired value following the conditions listed below.

- FRAMERATE can be set from 100frame rates between 60 fps (50fps for PAL) and 75,000 fps.
- The size and horizontal position of the resolution can be set in 256 (horizontal) and 32(vertical) increments.

3.8. White Balance Adjustment (Color Models Only)

On digital video cameras, photographing white as pure white is described as "having the appropriate white balance." On the system's color models in order to take images with the correct color representation, the white balance must be adjusted for the color temperature of the light source used. The intensity of each color, R, G, and B, can be adjusted independently on this system. By adjusting the balance of those three colors to match the light source used, the appropriate white balance can be achieved.

Two methods are available for adjusting the white balance, preset and user-editable white balance. These methods are explained in this section.

3.8.1. Using Preset White Balance (Color Models Only)

With the system, there are two white balance presets (5100K, 3100K) for use with common light sources. The suggested color temperature for these presets is listed below.

5100K (Daylight, Outdoors)

3100K (Halogen Light Source)

3.8.2. Using User White Balance (Color Models Only)

User white balance can be set in order to achieve the most appropriate white balance for the light source used with the system and the conditions during recording.

The values set here are stored in the camera body's internal memory as the user preset, and they can be loaded by selecting USER.

There are also two methods for setting user white balance, AUTO USER and EDIT USER.

3.9. Color Enhancement Function (Color Models Only)

Color models feature an image color enhancement setting. The image color enhancement level can be adjusted in five steps, including the OFF setting.

3.10. LUT (Look-Up Table) Operations

The LUT (Look-Up Table) refers to a reference table that defines the relationship between the pixel brightness gradation of the original image data taken and the brightness gradation displayed on a computer screen or video monitor.

The system contains a hardware LUT function, and you can display the image data taken with improved contrast (light and dark sharpness) or make an object in the image stand out by emphasizing a specified gray level range.

The LUT in the system and the relationship between it and video output and the PC software is explained below.



Caution

- When an image is saved with its brightness converted with the LUT, the image saved is the image that has had its brightness converted.

◆ D1: Gain 1x

The input is always linear display. This LUT is used for normal conditions.

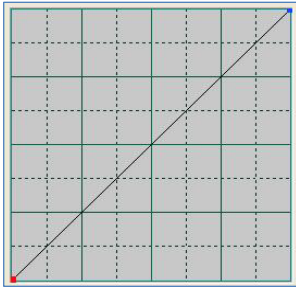

◆ D2: Gain 2x

The gain is doubled and you can display the dark areas of the image emphasized.

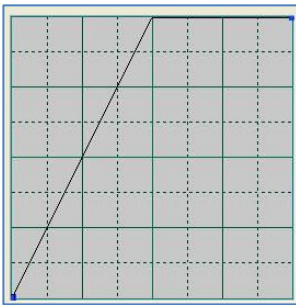

◆ D3: Gain 4x

The gain is quadrupled and you can display the dark areas of the image emphasized. This LUT emphasizes the dark portions even more than D2.

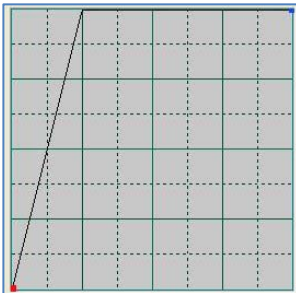

◆ D4: Gamma 0.56

This LUT is 0.56 gamma correction. The optimum Gamma for a MAC monitor.

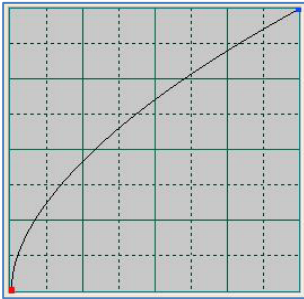

◆ D5: Gamma 0.56 Gain 2x

A LUT of doubled GAIN at Gamma 0.56.

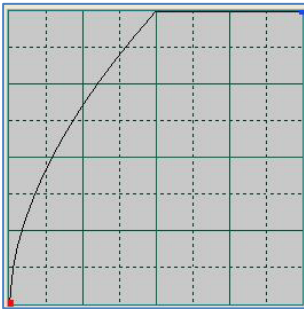

◆ D6: Gamma 0.56 Gain 4x

A LUT of quadrupled GAIN at Gamma 0.56.

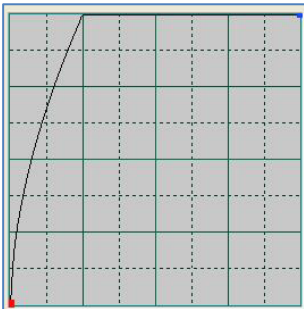

◆ D7: Gamma 0.45

This LUT is 0.45 gamma correction. The optimum Gamma for a video monitor.

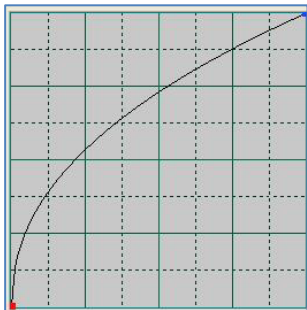

◆ D8: Gamma 0.45 Gain 2x

A LUT of doubled GAIN at Gamma 0.45.

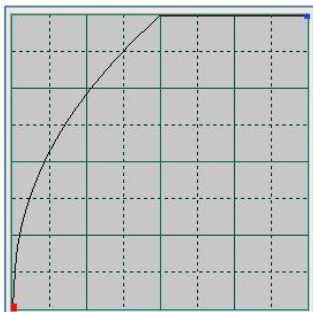

◆ D9: Gamma 0.45 Gain 4x

A LUT of quadrupled GAIN at Gamma 0.45.

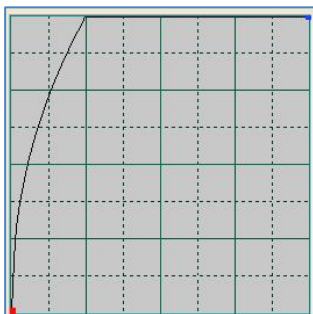

3.10.1. Using a Custom LUT

Creating a LUT pattern is done with PFV.

Reference

- For the creation method of a LUT pattern, refer to “Photron FASTCAM Viewer User's Manual”.

3.11. Edge Enhancement Function

With the system's edge enhancement setting, you can enhance the edges in the recorded image in three steps. This can be useful when automated motion analysis is to be used.

Menu Display	Contents
OFF	Edge enhancement off.
LEVEL1	Edge enhancement set to weak.
LEVEL2	Edge enhancement set to medium.
LEVEL3	Edge enhancement set to strong.

3.12. Black Adjust Level

For this product, eight stages to adjust the black level can be set.

3.13. Partition Memory & Record

The standard system contains 8GB internal memory, or a maximum of 32GB, of high-capacity memory for recording use.

This recording memory can be partitioned and assigned to each recording. Memory is partitioned into equal sizes and a maximum of 64 partitions can be set. The partitioned sections are managed by ID numbers.

Each section can be set with completely independent recording conditions, so this feature is convenient when taking consecutive recordings with changed conditions.



Important

- Only the following trigger modes are valid when the partition mode is operating in "MODE2".
"START", "CENTER", "END", "MANUAL"

3.14. Input/Output Signal Types

With the system, many signals can be input and output through the I/O cable. Signals that can be input and output from the I/O cable are listed below.



A signal other than the specified signal must not be input to the various connectors.

Use extreme caution as there is a risk of damage to both devices, the input device and the output device.

3.14.1. TRIG TTL IN Connector

The system recognizes an external TTL signal as a trigger during the READY or ENDLESS recording state. Starting and stopping recording (in the selected recording mode) is controlled with this signal.

Input voltage is 0V to +12V (H level +4.5V to +12V), positive or negative polarity, pulsewidth is 50 ns or greater.

Operating current is 10 mA recommended, 30 mA maximum.

3.14.2. TRIG TTL OUT Connector

A 5V TTL trigger signal is output for input to an external device.

3.14.3. TRIG SW IN Connector

This trigger is input during the READY or ENDLESS recording state by contact between the BNC connector's shield and a center pin (switch closure). The center pin normally has voltage flowing through it. Use caution to avoiding contact with other pins.

3.14.4. SYNC IN Connector

The system recognizes a TTL signal from other devices as a synchronization signal.

Input voltage is 0V to +12V (H level +4.5V to +12V), positive or negative polarity, pulsewidth is 50 ns or greater.

Operating current is 10 mA recommended, 30 mA maximum.

3.14.5. GENERAL IN Connector

Input voltage is 0V to +12V (H level +4.5V to +12V), positive or negative polarity, pulsewidth is 50 ns or greater.

Operating current is 10 mA recommended, 30 mA maximum.

EVENT POS/NEG	Inputs an event signal (event marker).
TRIG POS/NEG	Inputs a TTL trigger signal.
READY POS/NEG	Inputs a change recording ready status signal (READY ON/OFF).

3.14.6. GENERAL OUT (1,2,3) Connector

(POS: positive polarity, NEG: negative polarity)

SYNC POS/NEG	Outputs a vertical synchronization signal.
EXPOSE POS/NEG	Outputs the camera's exposure period signal. * Outputs during both LIVE and recording.
REC POS/NEG	Outputs a signal during recording.
TRIG POS/NEG	Outputs the trigger signal the camera received.
READY POS/NEG	Outputs a signal that indicates the recording ready state.

3.15. Using External Triggers

With the system, you can record by receiving various trigger signals matched to the recording application. The trigger signals that can be used on the system are explained here, along with a description of how to use them.

3.15.1. Inputting an External Trigger Signal

The external trigger signals that can be used with the system and their input system are listed below. External trigger signal input settings are also made by selecting [SYNC IN/OUT] from the menu and [TRIG TTL IN] or [GENERAL IN] from the submenu.

The signals input from the TRIG TTL IN and GENERAL IN connectors are explained in section "2.2.7. I/O Port Connector".

Connector Name	Menu	Signal
TRIG TTL IN	TRIG POS	Isolated IC Input
		0V - +12V (H level +4.5 - +12V), Positive Polarity
	TRIG NEG	Isolated IC Input
		0V - +12V (H level +4.5 - +12V), Negative Polarity
GENERAL IN	TRIG POS	Isolated IC Input
		0V - +12V (H level +4.5 - +12V), Positive Polarity
	TRIG NEG	Isolated IC Input
		0V - +12V (H level +4.5 - +12V), Negative Polarity
TRIG SW IN	None	Contact signal

When a trigger signal is input to GENERAL IN, set the signal to be input from the menu in advance before using it.



Use caution not to input more than specified voltage or current to the TRIG TTL IN and GENERAL IN trigger signal inputs as there is a risk of damage to the equipment.

Reference

- For the setting method of the signal inputted into GENERAL IN, refer to "3.17.1. GENERAL IN Signal Settings", page 55.

◆ TRIG TTL IN Circuit Diagram

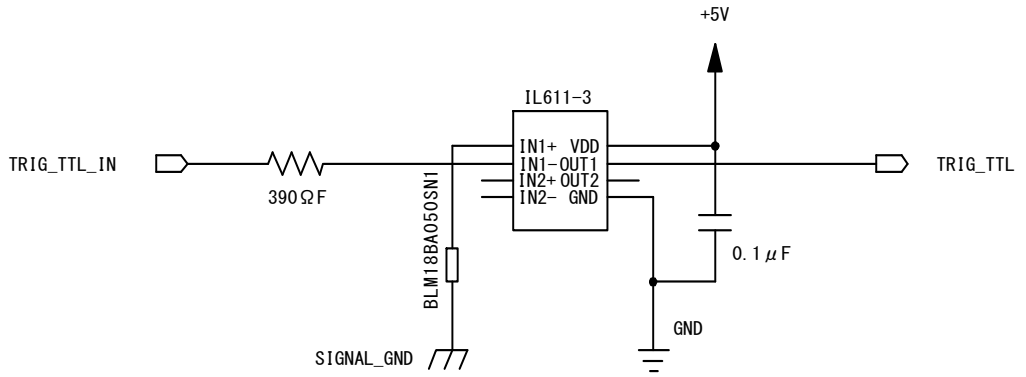

◆ GENERAL TTL IN Circuit Diagram

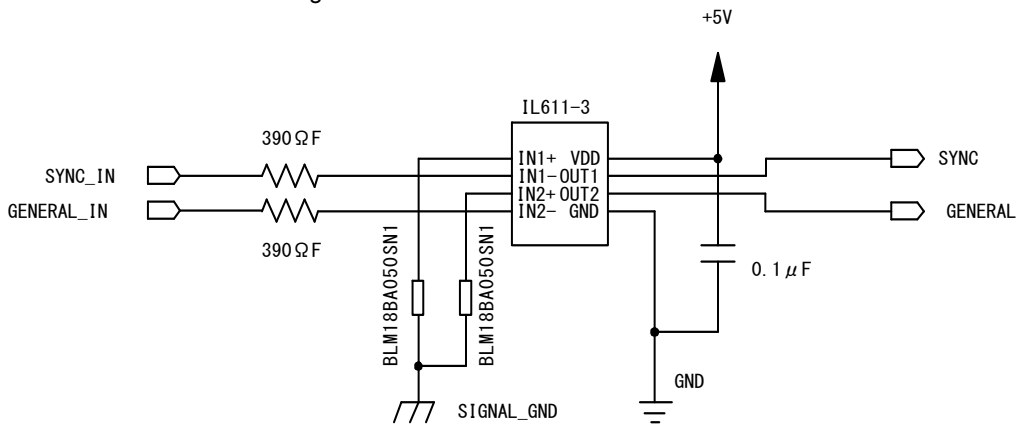

◆ TRIG SW IN Circuit Diagram

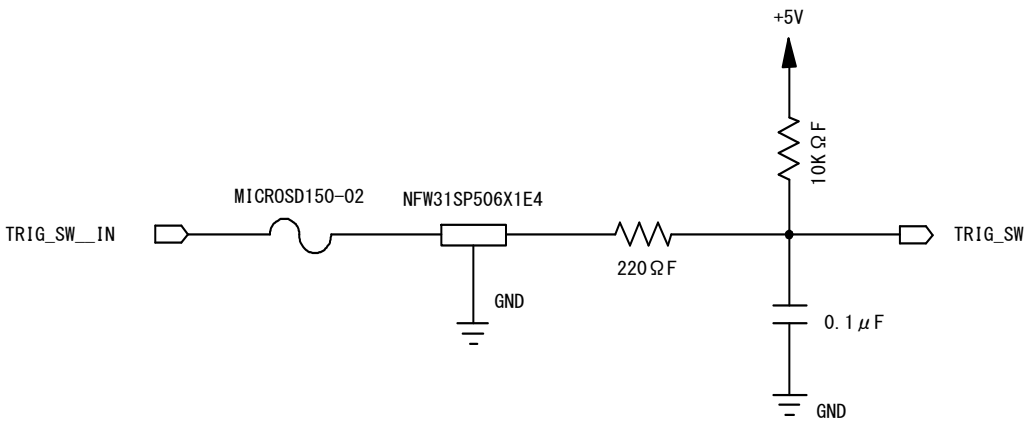

3.15.2. Outputting External Trigger Signals

With the system, you can externally output trigger signals. Output is performed with the TRIG TTL OUT connector's dedicated trigger output system provided by the system, and additionally, output can also be optionally set from the GENERAL OUT connector. External trigger signal output settings are also made by selecting [SYNC IN/OUT] from the menu and [TRIG TTL] OUT or [GENERAL OUT] from the submenu.

Signal output is performed from the TRIG TTL OUT connector and the GENERAL OUT connector explained in section "2.2.7. I/O Port Connector".

The chart below summarizes the output systems and the signals that can be output.

Connector Name (Output System)	Menu Setting	Signal Type	Reference Delay Amount
TRIG TTL OUT	TRIG POS	TTL, SW, SOFT, all TRIG pulse output CMOS (74ACT541 buffer) output, Positive Polarity.	For TRIG SW IN, approx. 24 usec. For TRIG TTL IN, approx. 100nsec.
	TRIG NEG	TTL, SW, SOFT, all TRIG pulse output CMOS (74ACT541 buffer) output, Negative Polarity.	
	TTL IN THRU POS	TRIG TTL IN through output CMOS (74ACT541 buffer) output, Positive Polarity.	For TRIG TTL IN, approx. 50nsec.
	TTL IN THRU NEG	TRIG TTL IN through output CMOS (74ACT541 buffer) output, Negative Polarity.	
GENERAL OUT	TRIG POS	TTL, SW, SOFT, all TRIG pulse output CMOS (74ACT541 buffer) output, Positive Polarity.	For TRIG SW IN, approx. 24usec. For TRIG TTL IN GENERAL IN, approx. 100nsec.
	TRIG NEG	TTL, SW, SOFT, all TRIG pulse output CMOS (74ACT541 buffer) output, Negative Polarity.	

3.16. Using External Synchronization Signals

An external synchronization mode to synchronize to an external signal is provided on the system. By using an external synchronization signal, recording can be conducted using multiple cameras to synchronize the timing of the shots or to also synchronize the shots with external measuring devices and lighting. The procedure and precautions for using the external synchronization signal are explained below.

3.16.1. Inputting an External Synchronization Signal

An external synchronization signal can be input with the system. See the chart below for external synchronization input settings.

Menu Display	Contents	Signal (Input Signal Conditions)
OFF	Turns external synchronization off, operates independently.	(none)
ON CAM POS	Synchronizes to a positive polarity signal from the system.	TTL Level, Positive Polarity
ON CAM NEG	Synchronizes to a negative polarity signal from the system.	TTL Level, Negative Polarity
ON OTHERS POS	Synchronizes to a positive polarity signal from an external device (including other Photron products).	TTL Level, Positive Polarity
ON OTHERS NEG	Synchronizes to a negative polarity signal from an external device (including other Photron products).	TTL Level, Negative Polarity

3.16.2. Outputting an External Synchronization Signal

The system can externally output a synchronization signal. Output of the external synchronization signal is performed from the GENERAL OUT connector explained in section "2.2.7". See the chart below for external synchronization output settings.

Menu Display	Contents	Signal Type	I/O delay amount
SYNC POS	Outputs a positive polarity vertical synchronization signal.	CMOS (74ACT541 buffer) output, positive polarity	Approx. 160nsec
SYNC NEG	Outputs a negative polarity vertical synchronization signal.	CMOS (74ACT541 buffer) output, negative polarity	Approx. 170nsec

3.16.3. Synchronizing Multiple FASTCAM SA6 Systems (Multiple Unit Synchronized Recording)

The system can perform synchronized recording by synchronizing multiple units using external.

◆ Synchronization input/output

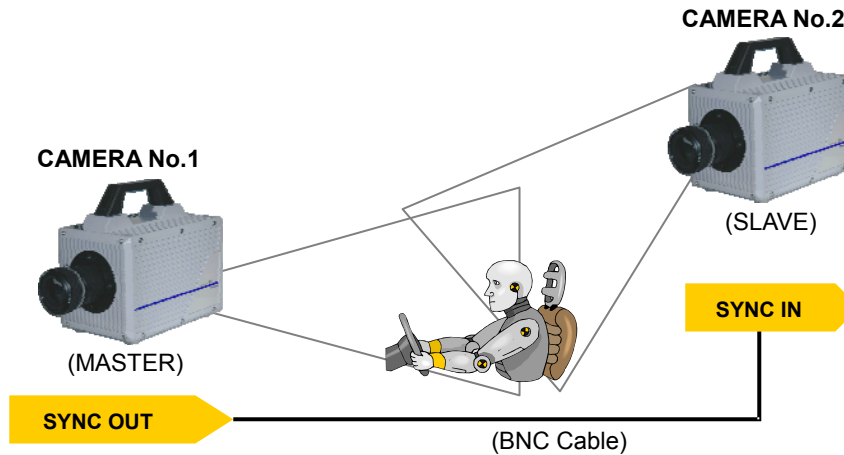

Synchronized recording settings using the system are made with the "LCD remote controller (optional)" or PFV. The conceptual settings when performing synchronized recording using two systems are explained here. First, decide which camera to make the master camera (outputs the synchronization signal) and the slave camera (receives the synchronization signal) from the two systems to use for synchronized recording.

◆ Setting the Master Camera (Outputs Synchronization)

Set the signal output for the master camera which will output the synchronization signal. Synchronization signal settings are made with the "LCD remote controller (optional)" or PFV.

■ For PFV (Standard)

1. Verify that the camera mode is in LIVE mode (the image displayed is passed through from the camera). If the system is in a mode other than LIVE mode, check "Live" on the camera control panel.
2. Select I/O on the left tree from "Camera Option" on the camera control panel.
3. Set "GENERAL OUT1".

■ For the LCD Remote Controller (Optional)

1. Press the LCD remote controller's MENU key and the menu list is displayed.
2. Select GENERAL OUT1 from the SYNC IN/OUT submenu with the LCD remote controller's ARROW keys and press the ENTER key.
3. From the menu, select the signal to output from the master camera's GENERAL OUT1 connector. Move the cursor to the SYNC POS item with the ARROW keys and press the ENTER key to select.

4. The master camera is set to output a positive polarity vertical synchronization signal from its GENERAL OUT1 connector.

◆ **Setting the Slave Camera (Receives the Synchronization Signal)**

Next, set the synchronization signal input for the slave camera which will receive the synchronization signal supplied by the master camera. Synchronization signal settings are made with the "LCD remote controller (optional)" or PFV.

■ **For PFV (Standard)**

1. Verify that the camera mode is in LIVE mode (the image displayed is passed through from the camera). If the system is in a mode other than LIVE mode, check "Live" on the camera control panel.
2. Select I/O on the left tree from "Camera Option" on the camera control panel.
3. Set SYNC IN to "ON CAM POS".

■ **For the LCD Remote Controller (Optional)**

1. Input the slave camera's synchronization. Connect the slave camera's SYNC IN connector with the master camera's GENERAL OUT1 connector using a BNC cable. When the synchronization signal is input to the SYNC IN connector, the SYNC IN LED (yellow) on the rear of the slave camera illuminates.
2. Set the synchronization signal type that slave camera will receive. Press the LCD remote controller's MENU key and the menu list is displayed.
3. Select SYNC IN from the SYNC IN/OUT submenu with the LCD remote controller's ARROW keys and press the ENTER key.
4. The output previously set on the master camera has positive polarity (POSITIVE), therefore it is necessary to make the setting on the slave camera controller the same, positive polarity (POSITIVE). Move the cursor to the ON CAM POS item with the ARROW keys and press the ENTER key to select.



Important

- If steps, 2 to 4 are completed when no synchronization signal is being input, the camera will not operate normally. As detailed in the procedure, make the settings when the signal is being input.

3.16.4. Synchronizing the System with Other External Devices (Frame Rate Synchronized Recording)

With the system, in addition to the frame rate preset in the system, a function has been provided where you can receive a synchronization signal externally, set the frame rate to that frequency, and record.

In this way, for example, the system can be synchronized with a dynamic body that spins at 1,350 revolutions a second to conduct high-speed recording at 1,350 fps. This can open up broad applications that were unavailable until now.

◆ Conceptual Diagram of External Synchronized Recording

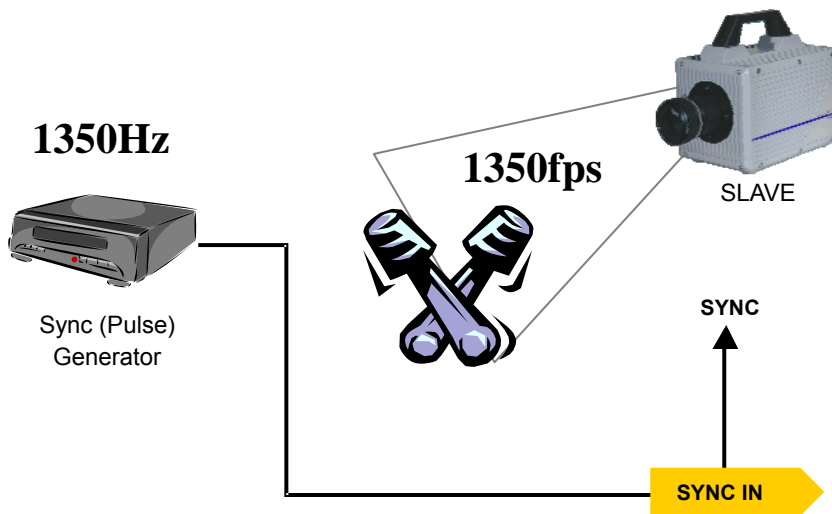

Important

- When conducting frame rate synchronization recording with the system, the signal that can be input must meet the following conditions.
 - TTL level, positive polarity or negative polarity
 - 60 Hz (50 Hz for PAL) to 75,000 Hz

◆ System Settings

Frame rate synchronization signal settings on the system are made with the "LCD remote controller (optional)" or PFV.

- For PFV (Standard)
 1. Verify that the camera mode is in LIVE mode (the image displayed is passed through from the camera). If the system is in a mode other than LIVE mode, check "Live" on the camera control panel.
 2. Select I/O on the left tree from "Camera Option" on the camera control panel.
 3. Set SYNC IN to "ON OTHERS POS/NEG".

■ For the LCD Remote Controller (Optional)

1. Input the synchronization signal from the device that generates the signal to the system. Connect the synchronizing device's output signal to the system's SYNC IN connector using a BNC cable.
2. When the synchronization signal is input to the SYNC IN connector, the SYNC IN LED (yellow) on the rear of the system illuminates. (* If the synchronization signal is lost, the LED goes out.)
3. Press the LCD remote controller's MENU key and the menu list is displayed.
4. Select SYNC IN from the SYNC IN/OUT submenu with the LCD remote controller's ARROW keys and press the ENTER key.
5. Use the LCD remote controller's ARROW keys to select the input signal. Select ON OTHERS POS (positive polarity) or ON OTHERS NEG (negative polarity) according to the polarity of the external synchronization signal.
6. When the setting is complete, press the ENTER key to finish.
7. Output the signal from the synchronization device and verify that the system recognizes the output frequency and synchronizes its frame rate. The recognized frame rate will display in the lower left of the video monitor.



Caution

- The frequency of the synchronization signal cannot be changed during LIVE or recording. (This is out of spec assurance.) The synchronization signal can be changed if you repeat steps 1 through 7 after inputting the changed frequency. The system is reset.
- If no synchronization signal is input or the input signal is under 60Hz (50Hz) during steps 3 to 7, or the synchronization signal is lost, the display shows "NO SYNC INPUT".
If steps 3 through 7 are done inputting a signal over 75,000Hz, the display shows "OVER SYNC INPUT".
In either case, you cannot record normally.
- A minute error occurs in the input synchronization signal due to the construction of the internal circuitry of this function.
An error of ± 18.5 ns occurs for the input synchronization signal in the actual operation.
Since the frame rate display value on the monitor is in 1Hz units, the error may be shown larger than the actual operation (an error of about ± 1 -5Hz is produced).
For example, when performing external device synchronization inputting a synchronization signal of 10000Hz, the monitor display error is:
 $10,000 \text{ Hz} \pm 1\text{Hz} = 9,999 \text{ fps to } 10,001 \text{ fps}$.

3.16.5. Synchronizing the System with Other Cameras

(Mixed Device Synchronized Recording)

Using the function (frame rate synchronization recording) in the previous section, "3.16.4.

Synchronizing the System with Other External Devices

(Frame Rate Synchronized Recording)", mixed-type synchronized recording can be performed with Photron's other high-speed cameras (except for some older products).

In particular, the FASTCAM SA1.1, FASTCAM SA3, FASTCAM APX-RS, and FASTCAM MH4-10K are compatible with collective control by the PFV control software.

◆ Basic Process

1. Decide the master camera (the source of the synchronization signal) and the slave camera (the camera that will operate according to the synchronization signal from the master). Basically, by making the master camera the camera with the lowest maximum frame rate that can be set, you can avoid setting a synchronization signal speed the slave camera cannot receive.
2. Connect the master camera's V-SYNC output connector to the slave camera's V-SYNC input connector with a BNC cable, select the synchronization signal output polarity on the master camera, and then set the slave camera to be operated by that signal.

For camera models that can perform synchronized recording or for detailed instructions on making the settings, contact Photron at the contact information in "7.1. Contact Information"

3.17. GENERAL Signal Settings

3.17.1. GENERAL IN Signal Settings

Details of the signals output from the GENERAL OUT connector explained in section “3.14. Input/Output Signal Types” are shown in the chart below.

Menu Display	Contents	Signal (Input Signal Conditions)
EVENT POS	Inputs a positive polarity event signal.	TTL Level, Positive Polarity
EVENT NEG	Inputs a negative polarity event signal.	TTL Level, Negative Polarity
TRIG POS	Inputs a positive polarity trigger signal.	TTL Level, Positive Polarity
TRIG NEG	Inputs a negative polarity trigger signal.	TTL Level, Negative Polarity
READY POS	Inputs a positive polarity READY signal. READY ON/OFF is switched by a pulse input.	TTL Level, Positive Polarity
		TTL Level, Negative Polarity
READY NEG	Inputs a negative polarity READY signal. READY ON/OFF is switched by a pulse input.	TTL Level, Positive Polarity
		TTL Level, Negative Polarity



When using the camera as a part of a system, verify the characteristics of the input signals before using them.

Reference

- For the details of an EVENT POS/NEG setup, refer to “3.19. Event Marker Function”, page 58.

3.17.2. GENERAL OUT Signal Settings

Details of the signals output from the GENERAL OUT connector explained in section “3.14. Input/Output Signal Types” are shown in the chart below. There are three GENERAL OUT connectors and individual settings can be made for each connector.

Menu Display	Contents	Signal Type
SYNC POS	SYNC POS; Outputs a positive polarity vertical synchronization signal.	TTL level, Positive Polarity
SYNC NEG	SYNC NEG; Outputs a negative polarity vertical synchronization signal.	TTL level, Negative Polarity
EXPOSE POS	Outputs the image sensor's exposure interval at H level.	TTL level, Positive Polarity
EXPOSE NEG	Outputs the image sensor's exposure interval at L level.	TTL level, Negative Polarity
REC POS	REC POS; Outputs an interval signal during recording at H level.	TTL level, Positive Polarity
REC NEG	REC NEG; Outputs an interval signal during recording at L level.	TTL level, Negative Polarity
TRIG POS	Outputs the trigger signal received by the camera at H level.	TTL level, Positive Polarity
TRIG NEG	Outputs the trigger signal received by the camera at L level.	TTL level, Negative Polarity
READY POS	Outputs a signal at H level during the trigger wait state. (READY in START mode.) Only valid during START, CENTER, END, and MANUAL modes.	TTL level, Positive Polarity
READY NEG	Outputs a signal at L level during the trigger wait state. (ENDLESS recording state in CENTER, END, MANUAL) Only valid during START, CENTER, END, and MANUAL modes.	TTL level, Negative Polarity
IRIG RESET POS	Outputs the camera's internal IRIG reset signal (1PPS) at H level.	TTL level, Positive Polarity
IRIG RESET NEG	Outputs the camera's internal IRIG reset signal (1PPS) at H level.	TTL level, Negative Polarity



When using as a part of a system, verify the characteristics of the output signals before using them.

3.18. Signal Delay

With the system, you can set the signal delay time or pulsewidth for the various signals that are input and output. Pulse width and delay settings for the various signals to input/output are made with PFV or the LCD remote controller (optional). The content of each setting is listed in the chart below.

Setting Item	Setting Range (Value)
TRIG TTL IN DELAY	0-60 (s) 100 ns units
SYNC IN DELAY	0-1/frame rate (s) 100 ns units
GENERAL IN DELAY	0-60 (s) 100 ns units
TRIG OUT WIDTH	0-1 (ms) 100 ns units
SYNC OUT DELAY	0-1/frame rate (s) 100 ns units
SYNC OUT WIDTH	0-500 (us), 1/frame rate (s) at 2,000 fps or higher 100 ns units
EXPOSE OUT DELAY	0-1/frame rate (s) 100 ns units
SYNC OUT TIMES	0.5, 1, 2, 4, 6, 8, 10, 20, 30 (* x1 is standard output)

◆ SYNC OUT TIMES

Outputs SYNC (vertical synchronization signal) from SYNC OUT that is X times SYNC. However, when the frame rate is set to 60,000 fps or higher, x30 cannot be set.

Example: For a frame rate of 1,000 fps, SYNC OUT TIMES setting of 2.

1,000 fps Synchronization Signal

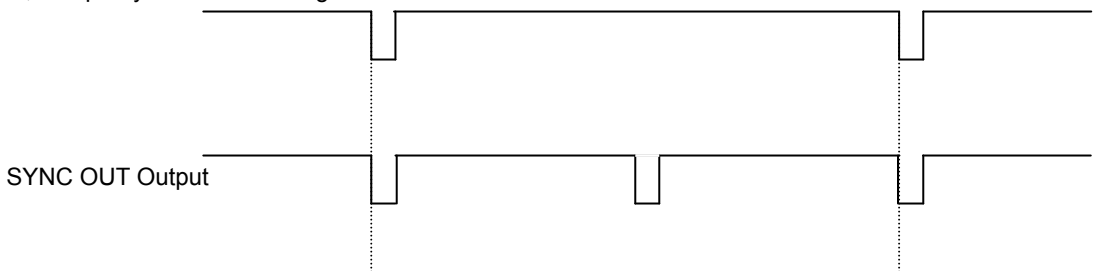

Example: For a frame rate of 1000 fps, SYNC OUT TIMES setting of 4.

1,000 fps Synchronization Signal

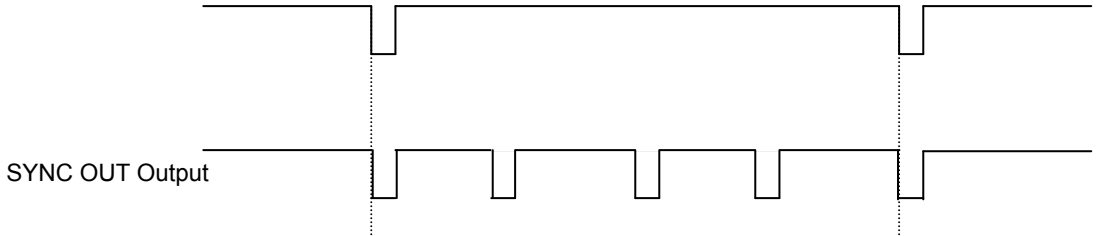

Caution

- An accurate frequency is output, but when SYNC OUT TIMES is set to a large value with a high frame rate, the setting may result in frequency errors.

3.19. Event Marker Function

With the system, it is possible to input an external signal during recording, at the instant the frame number is stored, and during playback you can immediately access, or jump to, the stored frame numbers (event markers). This a separate feature from the trigger point, by marking interesting points during recording, these points can be easily called up for review during playback. The event marker can store ten positions within a sequence.

The frame number recording occurs on the pulse's edge, and the next frame after the pulse's edge is input is stored as the event marker. Event marker settings can be made with the "LCD remote controller (optional)" or PFV.

3.20. Using USER SW (Programmable Switch)

There are four switches that can be set on the back of the system. Settings for the switches are made from the menu and they can each be assigned a different function. The content of each setting is listed in the chart below.

◆ PFV

Setting	Explanation
OFF	Does not assign a function.
Change Frame Rate	Raises the frame rate
Change Resolution	Lowers the resolution
Change Shutter Speed	Increases the shutter speed.
Change Trigger Mode	Changes the trigger mode.
Image Fit	Adjusts the size of the image displayed on the video output to fit fully on the display used.
Status Display	Displays the status of camera settings on the video output.
Switch LIVE/MEMORY	Switches between LIVE and MEMORY states.
Record Ready	Sets the record ready state.
Record	Starts recording.
Low-Light	Turns low-light mode ON/OFF.
Calibrate	Performs black level calibration. Press this button once and the LEDs on the back of the camera illuminate back and forth from left to right and from right to left to inform you of the ready state. Afterwards, with the sensor shielded, press the button once more to complete calibration.

◆ LCD Remote Controller (Optional)

Setting	Explanation
OFF	Does not assign a function.
FRAMERATE SEL	Raises the frame rate.
FRESOLUTION SEL	Lowers the resolution
SHUTTER SEL	Increases the shutter speed.
TRIGGER SEL	Changes the trigger mode
FIT	The same function as the [FIT] key on the keypad.
STATUS	The same function as the [STATUS] key on the keypad.
LIVE	The same function as the [LIVE] key on the keypad.
REC READY	The same function as the [REC READY] key on the keypad.
REC	The same function as the [REC] key on the keypad.
LOW LIGHT	The same function as the [LOW LIGHT] key on the keypad.
CALIBRATE	The same function as the [CALIBRATE] key on the keypad.

3.21. Using MCDL (Analog Waveform Synchronized Recording Unit)

The system supports an optional MCDL (analog waveform synchronized recording unit). The waveform data (analog 4 ch. max., digital 6 ch.) output from the MCDL is sampled, synchronized with the image and can be saved. The sampling rate is 10 times the frame rate and the timing of the sample is 1/10th of the interval of each frame rate. The saved data can be played as a waveform image with the "Photron FASTCAM Viewer" software.

Caution

• About MCDL, IRIG restrictions

This applies only to the 32GB model. Since there is a large amount of memory for images, with the resolution settings specified below, there are too many images that can be obtained in total and the analog data for the same amount of frames cannot be saved in the MCDL/IRIG save data memory. If the resolution is set to these settings, MCDL ON (or MCDL IRIG ON) is not valid, even if selected. If MCDL ON (or MCDL IRIG ON) is set when the resolution is lowered to the resolutions specified below, the MCDL ON (or MCDL IRIG ON) setting is cleared.

Restrictions for 32 GB model only

	IRIG	MCDL	IRIG/MCDL
256x32	○	×	×
256x64 or more (More than 16384 pixels)	○	○	○

○ Recordable

× Not recordable

3.22. IRIG Time Code (External Time Synchronization)

The system supports IRIG-B input and can add an IRIG code to each recorded frame. The sample timing for the IRIG code is once each frame.

The recorded IRIG code is displayed on the VIDEO display or with the “Photron FASTCAM Viewer” software.

◆ IRIG Code Input Specification

Connector	BNC
Code Format	IRIG-B (122) Analog
Amplitude	1.2Vp-p min,8.0Vp-p
Modulation Ratio	2:1 to 4:1

Supplement

- When the IRIG code is being input, the IRIG code is displayed in white, and is displayed to the left.
- The IRIG offset time is also displayed below it. When the IRIG code is not being input, the IRIG code is displayed in grey. At that time, the counter is the camera’s internal counter and it continues to count.



Chapter. 4 **Connecting a PC**

4.1. Connecting the Gigabit Ethernet Interface to a PC

4.1. Connecting the Gigabit Ethernet Interface to a PC

The system can be controlled from a PC using the Gigabit Ethernet interface. This section explains the required setup when connecting the system to a PC.

Reference

- For operating instructions of Photron FASTCAM Viewer software, refer to "Photron FASTCAM Viewer User's Manual".

To connect a PC to the system, connect the system to a commercially available 1000BASE-T-compatible interface board with a LAN cable. For the LAN cable, prepare a UTP or STP Cat 5e (enhanced category 5) or higher LAN cable. (UTP: unshielded, STP: shielded) The maximum cable length between the PC and the system is, compliant to the 1000BASE-T specification, up to 100 m. One PC can connect to a maximum of 64 Photron Gigabit Ethernet interface equipped cameras using a hub. When connecting multiple devices, connect through a switching hub that can connect at 1000BASE-T. The maximum length of the cable that connects the system (or PC) to the switching hub is also 100 m.

◆ Settings

■ On the System

- IP Address Setting

■ On the PC

- IP Address Setting
- Packet Size
- Time Out Length
- Communications Port

! Important

- The system is only 1000BASE-T compatible. When using a PC compatible with only 10BASE-T or 100BASE-TX, the PC must be connected through a 10BASE-T, 100BASE-TX, and 1000BASE-T compatible switching hub.
- The system's factory default IP address is below:
IP ADDRESS > 192.168.0.10
NETMASK > 255.255.255.0
GATEWAY ADDRESS > 0.0.0.0
PORT > 2000 (Fixed, not changeable)

✍ Supplement

- Photron recommends using an STP cable over long distances or in noisy locations.

Reference

- For the setting method of IP address for camera system, refer to "4.1.2. Setting the IP Address", page 65.
- For the setting method of control PC, refer to "Photron FASTCAM Viewer User's Manual".

4.1.1. Connecting the System and a PC

Connect the LAN cable to the system as shown below.



Insert the LAN cable into the "GIGABIT ETHER" connector.

4.1.2. Setting the IP Address

Caution

- When connecting the system to a PC or when connecting other Gigabit Ethernet interface compatible Photron cameras, set each of those devices to a different IP address. Also, when connecting the system to an existing network, do not use IP addresses that are already in use on the network.

Reference

- For the procedure for setting the IP address of the system, refer to the "Photron FASTCAM Viewer User's Manual" or the "LCD Remote Controller User's Manual".

4.1.3. Using DHCP (Dynamic Host Configuration Protocol)

The system is compatible with DHCP. In an environment where DHCP is used, the system's IP address can be acquired from the DHCP server.

4.1.4. Connecting Multiple Systems and a PC

With PFV, the system's control software, one PC can connect to and control multiple FASTCAM high-speed camera system.

Caution

- When connecting to multiple systems, set the IP address of each one to a unique setting.

4.1.5. Gigabit Ethernet Interface Initialization

When you cannot communicate well with the camera even though you are running PFV, the system's control software, you may be able to improve the situation by performing the procedure below.

1. Of the four USER SW (programmable switches) on the back of the camera body, press and hold USER1 and USER4 for 10 seconds or more.
2. The LEDs on the rear of the camera body will illuminate back and forth from left to right and from right to left and inform you that the initialization of the Gigabit Ethernet interface has completed normally.

Chapter. 5 **Product Specifications**

5.1. Specifications

5.2. Dimensions

5.3. Cleaning the Filter

5.1. Specifications

5.1.1. Product Specifications

Image Sensor	CMOS image sensor	
Sensor Resolution	1,920 x 1,440 pixels	
Frame Rate	Maximum 1,125 fps with full frame resolution Maximum 75,000 fps when at reduced resolution	
Lens Mount	F mount and C mount supplied. PL mount (optional) BL mount (optional), Lens Mount with Filter Changer (Triple Type / Single Type) (optional)	
Recording Color Depth	Monochrome	12bit
	Color	RGB, each 12-bit (Bayer color filter method)
Shutter	Electronic shutter	
Recording Method	IC memory	
Recording Memory Capacity	8GB, 16GB, 32GB	
Trigger Method	START, CENTER, END, MANUAL, RANDOM, RANDOM RESET, RANDOM CENTER, RANDOM MANUAL, TWO STAGE	
Gain Control	The system contains a hardware LUT Controllable via keypad or software	
Image Output Customization	Customizable LUT with brightness conversion	
External Synchronization Input Signal	5 Vp-p, negative polarity/positive polarity (switchable)	
External Synchronization Output Signal	5 Vp-p, negative polarity/positive polarity (switchable)	
Trigger Input Signal	TTL, contact	
Other Output Signals	Other timing signal outputs, event marker input	
External Control	Keypad, RS-422 external control I/F, Gigabit Ethernet I/F (PC)	
Video Output Signal	NTSC/PAL, HD SDI (SMPTE 292M compliant) • NTSC mode 60i / 59.98i / 30p / 29.97p / 24p / 23.98p / 24p(sF) 23.98p(SF) • PAL mode 50i / 25p / 24p / 23.98p / 24p(sF) / 23.98p(sF)With digital zoom, scroll, fit functions	

5.1.2. General Specifications

Environment Conditions		
Storage Temperature		-20°C ~ 60°C (No Condensation)
Storage Humidity		Below 85% (No Condensation)
Guaranteed Operating Temperature	SA6	0 ~ 40°C (No Condensation)
	SA6 RV	0 ~ 45°C (No Condensation)
Guaranteed Operating Humidity		Below 85% (No Condensation)
Dimensions		
Camera Body	SA6	165 (H) × 153 (W) × 250 (D) mm Without Projections
	SA6 RV	165 (H) × 183 (W) × 250 (D) mm Without Projections
AC Power Supply Unit		49.7 (H) × 82 (W) × 207.6 (D) mm Without Projections
LCD Remote Controller		249.85 (H) × 150.4 (W) × 28.3 (D) mm Without Projections
AC Power Supply		
Power Supply Voltage		100V ~ 240V (Up to 125V for A type cable)
Power Supply FVoltage		50Hz ~ 60Hz
Power Consumption		100VA
DC Power Supply		
Power Supply Voltage		18V ~ 36V
Power Consumption		100VA
Weight		
Camera Body	SA6	6.9kg
	SA6 RV	8.5kg
AC Power Supply Unit		970 g
LCD Remote Controller (Option)		1.31 kg (No Handle)



Photron has verified two types of AC cables, type A (standard for Japan, USA, Canada, etc.) and type SE (standard for Germany, France, etc.). However, when those cables cannot properly receive power when plugged in, use the proper AC cable for the region's standards and verify that AC cable works properly.

For inquires regarding the recommended AC cable for each region, contact that region's Photron branch office or the distributor.

5.1.3. Options

User Option
LCD Remote Controller
PL Mount Kit
B4 Mount Kit
4 Output Trigger Box
MCDL Analog Waveform Synchronized Recording Unit
Dedicated Carrying Case
LCD Monitor Mounting Hardware
Accessory Mounting Hardware
Spare Power Supply Connector (For Custom Cable Creation)
LAN Connector Dust-Proof Cover
IDX Battery Cable
Application Mount Kit
Mechanical shutter



5.1.4. Frame Rate and Resolution

Image Size Frame (FPS)	1,920 x 1,440	1,920 x 1,088	1,920 x 1,080	1,920 x 1,024	1,920 x 800	1,920 x 512	1,536 x 1,080	1,536 x 512	1,536 x 480	1,024 x 1,024
50 (PAL)	○	○	○	○	○	○	○	○	○	○
60	○	○	○	○	○	○	○	○	○	○
125	○	○	○	○	○	○	○	○	○	○
250	○	○	○	○	○	○	○	○	○	○
500	○	○	○	○	○	○	○	○	○	○
1,000	○	○	○	○	○	○	○	○	○	○
1,125	○	○	○	○	○	○	○	○	○	○
1,500		○	○	○	○	○	○	○	○	○
2,000					○	○		○	○	
3,000						○		○	○	
4,000								○		
5,000										
6,000										
7,500										
8,000										
10,800										
21,600										
30,000										
45,000										
75,000										

The circle indicates a possible setting. The green items are the maximum resolution setting at that frame rate. This table is the list of default settings. Even finer settings are possible with the variable setting.

Image Size Frame (FPS)	1,024	1,024	768	512	512	512	256	256	256	256
	x 512	x 480	x 448	x 416	x 384	x 288	x 160	x 96	x 64	x 32
50 (PAL)	○	○	○	○	○	○	○	○	○	○
60	○	○	○	○	○	○	○	○	○	○
125	○	○	○	○	○	○	○	○	○	○
250	○	○	○	○	○	○	○	○	○	○
500	○	○	○	○	○	○	○	○	○	○
1,000	○	○	○	○	○	○	○	○	○	○
1,125	○	○	○	○	○	○	○	○	○	○
1,500	○	○	○	○	○	○	○	○	○	○
2,000	○	○	○	○	○	○	○	○	○	○
3,000	○	○	○	○	○	○	○	○	○	○
4,000	■	○	○	○	○	○	○	○	○	○
5,000	■	○	○	○	○	○	○	○	○	○
6,000	■	■	○	○	○	○	○	○	○	○
7,500	■	■	■	○	○	○	○	○	○	○
8,000	■	■	■	■	○	○	○	○	○	○
10,800	■	■	■	■	■	○	○	○	○	○
21,600	■	■	■	■	■	■	○	○	○	○
30,000	■	■	■	■	■	■	■	○	○	○
45,000	■	■	■	■	■	■	■	■	○	○
75,000	■	■	■	■	■	■	■	■	■	○

The circle indicates a possible setting. The green items are the maximum resolution setting at that frame rate. This table is the list of default settings. Even finer settings are possible with the variable setting.

5.1.5. Recordable Image Count/Resolution

Resolution	8G Model Rec. Frames	16G Model Rec. Frames	32G Model Rec. Frames
1,920x1,440	1,936	3,877	7,761
1,920x1,088	2,562	5,132	10,272
1,920 x 1,080	2,581	5,170	10,348
1,920 x 1,024	2,722	5,453	10,914
1,920 x 800	3,485	6,980	13,970
1,920 x 512	5,445	10,906	21,829
1,536x1080	3,441	6,894	13,798
1,536x512	7,260	14,542	29,105
1,536x480	7,744	15,511	31,046
1,024x1,024	5,445	10,906	21,829
1,024x512	10,890	21,813	43,658
1,024x480	11,616	23,267	46,569
768x448	16,595	33,239	66,527
512x416	26,807	53,694	107,467
512x384	29,041	58,168	116,423
512x288	38,722	77,558	155,230
256x160	139,400	279,210	558,830
256x96	232,334	465,351	931,384
256x64	348,501	698,026	1,397,077
256x32	697,002	1,396,053	2,794,154

* Recording Time = Rec. Frames x 1/frame rate (fps)

5.1.6. Shutter Speed List

Horizontal resolution	1,920	1,792	1,536	1,280	1,024	768	512	256
Shutter speed	50	50	50	50	50	50	50	50
	60	60	60	60	60	60	60	60
	100	100	100	100	100	100	100	100
	200	200	200	200	200	200	200	200
	300	300	300	300	300	300	300	300
	400	400	400	400	400	400	400	400
	500	500	500	500	500	500	500	500
	600	600	600	600	600	600	600	600
	700	700	700	700	700	700	700	700
	800	800	800	800	800	800	800	800
	900	900	900	900	900	900	900	900
	1,000	1,000	1,000	1,000	1,000	1,000	1,000	1,000
	2,000	2,000	2,000	2,000	2,000	2,000	2,000	2,000
	3,000	3,000	3,000	3,000	3,000	3,000	3,000	3,000
	4,000	4,000	4,000	4,000	4,000	4,000	4,000	4,000
	5,000	5,000	5,000	5,000	5,000	5,000	5,000	5,000
	6,000	6,000	6,000	6,000	6,000	6,000	6,000	6,000
	7,000	7,000	7,000	7,000	7,000	7,000	7,000	7,000
	8,000	8,000	8,000	8,000	8,000	8,000	8,000	8,000
	9,000	9,000	9,000	9,000	9,000	9,000	9,000	9,000
	10,000	10,000	10,000	10,000	10,000	10,000	10,000	10,000
	12,000	12,000	12,000	12,000	12,000	12,000	12,000	12,000
	15,000	15,000	15,000	15,000	15,000	15,000	15,000	15,000
	17,000	17,000	17,000	17,000	17,000	17,000	17,000	17,000
	20,000	20,000	20,000	20,000	20,000	20,000	20,000	20,000
	25,000	25,000	25,000	25,000	25,000	25,000	25,000	25,000
	30,000	30,000	30,000	30,000	30,000	30,000	30,000	30,000
	35,000	35,000	35,000	35,000	35,000	35,000	35,000	35,000
	40,000	40,000	40,000	40,000	40,000	40,000	40,000	40,000
	51,000	50,000	51,000	50,000	50,000	50,000	50,000	50,000
	62,000	60,000	60,000	60,000	60,000	61,000	60,000	60,000
	70,000	71,000	72,000	71,000	72,000	71,000	70,000	70,000
	80,000	80,000	81,000	83,000	82,000	80,000	80,000	81,000
	93,000	92,000	92,000	93,000	91,000	91,000	90,000	89,000
	102,000	99,000	99,000	99,000	102,000	100,000	102,000	99,000
	124,000	119,000	116,000	115,000	116,000	112,000	112,000	111,000
140,000	147,000	126,000	124,000	124,000	126,000	124,000	126,000	
159,000	167,000	156,000	149,000	146,000	146,000	149,000	156,000	
186,000	194,000	202,000	212,000	196,000	208,000	202,000	202,000	
277,000	283,000	289,000	295,000	256,000	266,000	277,000	261,000	
367,000	367,000	367,000	367,000	367,000	367,000	367,000	367,000	

The unit in the chart is 1/x s

 Supplement

- About the settable shutter

Settable shutter speeds differ with the horizontal width of the maximum resolution of the frame rate being used.

Example 1: When using 1,125 fps

The maximum resolution is 1,920x1,440, so the horizontal width is 1,920.

Shutter speeds that can be set at this setting are listed in the column titled 1,920.

(see the chart)

Since the frame rate is 1,125 fps, with a maximum exposure of 1/1,125 s, the shutter speeds are listed below.

- 1/1,125s
- 1/2,000s
- 1/3,000s
- ⋮
- 1/277,000s
- 1/367,000s

Example 2: When using 21,600 fps

The maximum resolution is 256x160, so the horizontal width is 256.

Shutter speeds that can be set at this setting are listed in the column titled 256.

Since the frame rate is 1,125 fps, with a maximum exposure of 1/1,125 s, the shutter speeds are listed below.

- 1/21,600s
- 1/25,000s
- 1/30,000s
- ⋮
- 1/261,000s
- 1/367,000s

Example 3: When created with variable frame rate, resolution function.

When a setting of 10,000 fps and a resolution of 256x32 is created and used, the maximum resolution is 256x32.

Shutter speeds that can be set at this setting are listed in the column titled 256.

Since the frame rate is 10,000 fps, with a maximum exposure of 1/10,000 s, the shutter speeds are listed below.

- 1/10,000s
- 1/12,000s
- 1/15,000s
- ⋮
- 1/202,000s
- 1/261,000s
- 1/367,000s

5.1.7. List of Frame Rates Selectable with the VARIABLE Setting

Selectable Frame Rate (fps)		
50	1,080	9,000
60	1,125	9,600
72	1,200	10,000
96	1,250	10,800
100	1,350	12,000
120	1,440	12,500
125	1,500	13,500
144	1,600	14,400
150	1,800	15,000
180	1,875	16,000
192	2,000	18,000
200	2,160	20,000
216	2,250	21,600
240	2,400	22,500
250	2,500	24,000
288	2,700	25,000
300	2,880	27,000
360	3,000	28,800
384	3,200	30,000
400	3,375	36,000
432	3,600	37,500
450	3,750	40,000
480	4,000	43,200
500	4,320	45,000
540	4,500	48,000
576	4,800	50,000
600	5,000	54,000
720	5,400	60,000
750	6,000	62,500
800	6,250	67,500
864	6,750	72,000
900	7,200	75,000
960	7,500	
1,000	8,000	

5.2. Dimensions

5.2.1. Camera Body

5.2.1.1. FASTCAM SA6 Body

(mm)

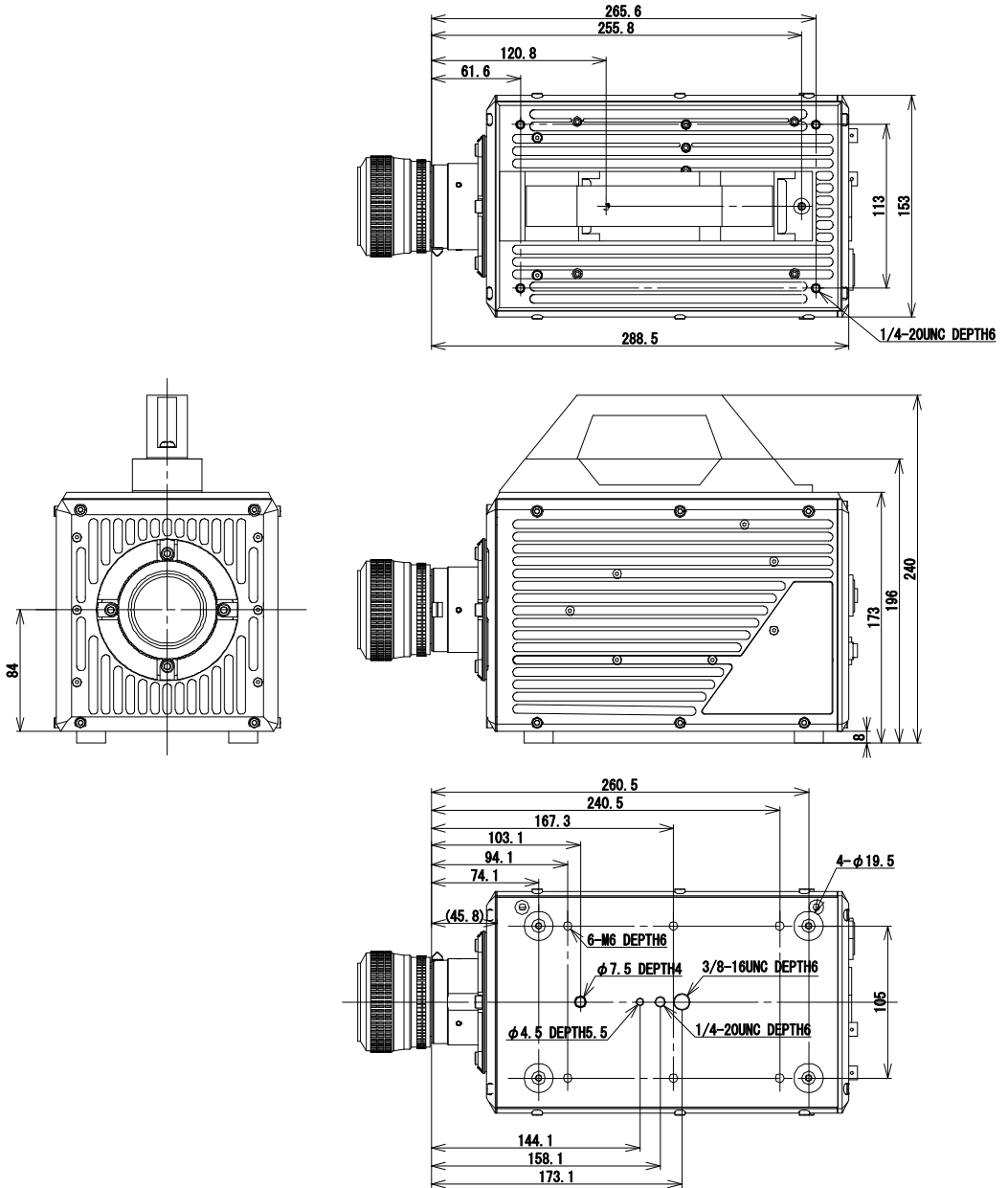

All dimensions are in millimeters

5.2.1.2. FASTCAM SA6 RV Body

(mm)

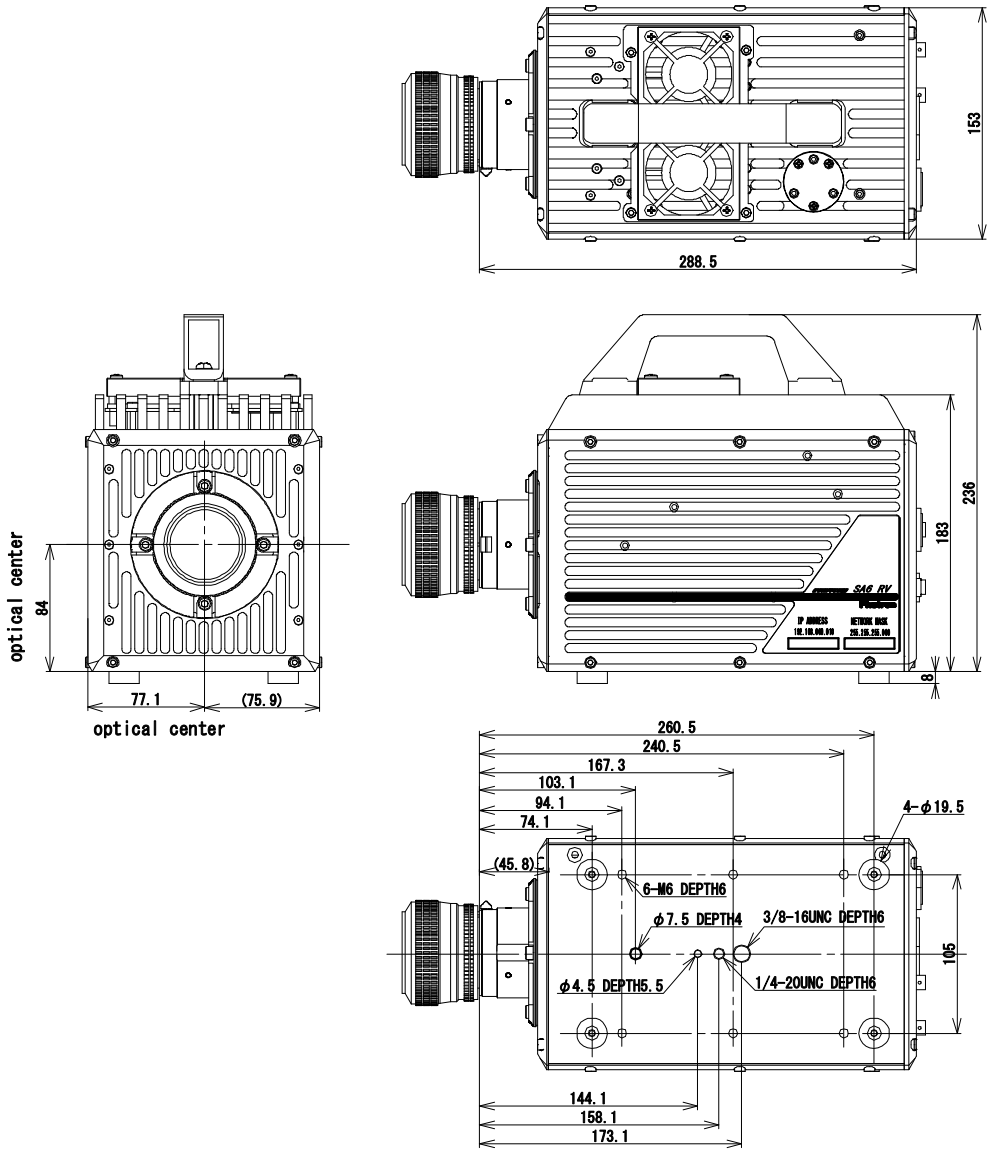

All dimensions are in millimeters

5.2.2. LCD Remote Controller (Optional)

(mm)

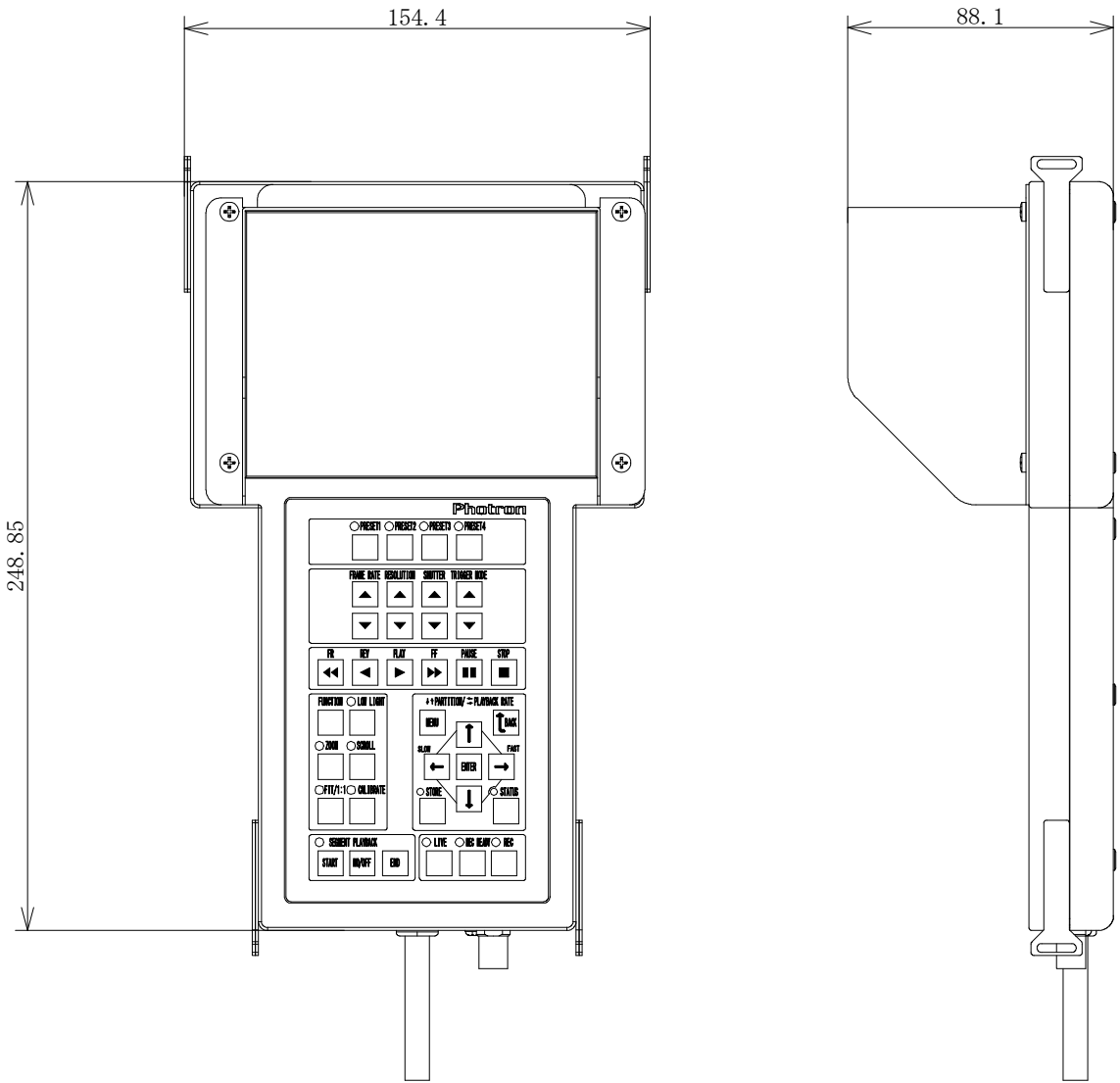

All dimensions are in millimeters

◆ Dimensions with Attached Handle
(mm)

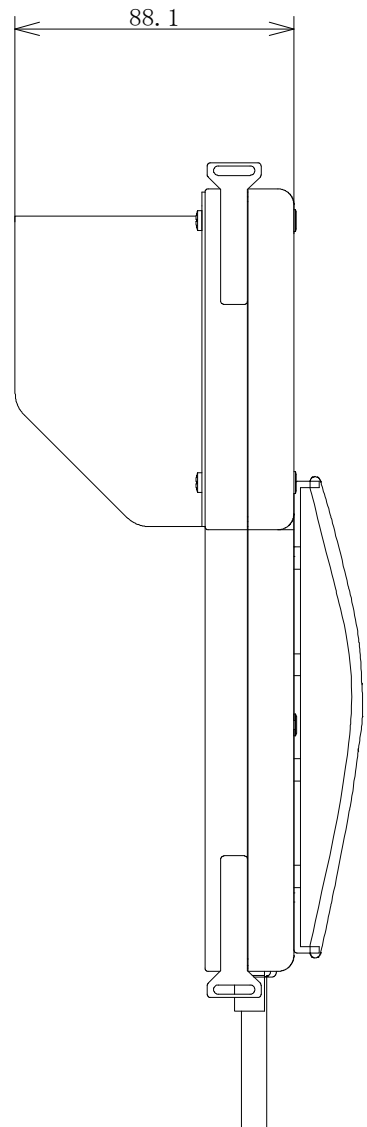
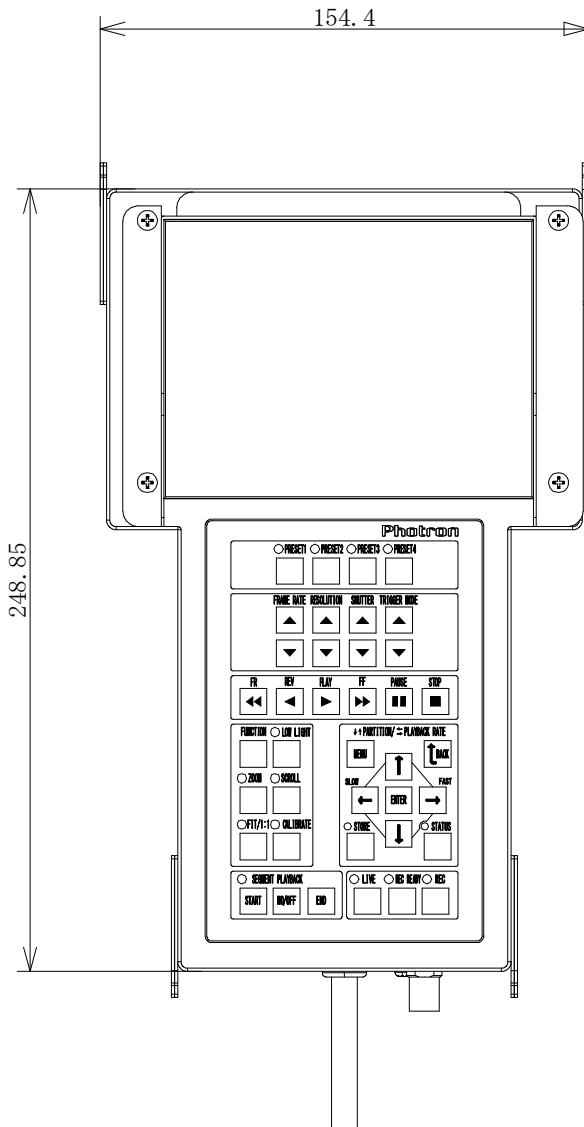

All dimensions are in millimeters

◆ Dimensions with Tripod Adapter
(mm)

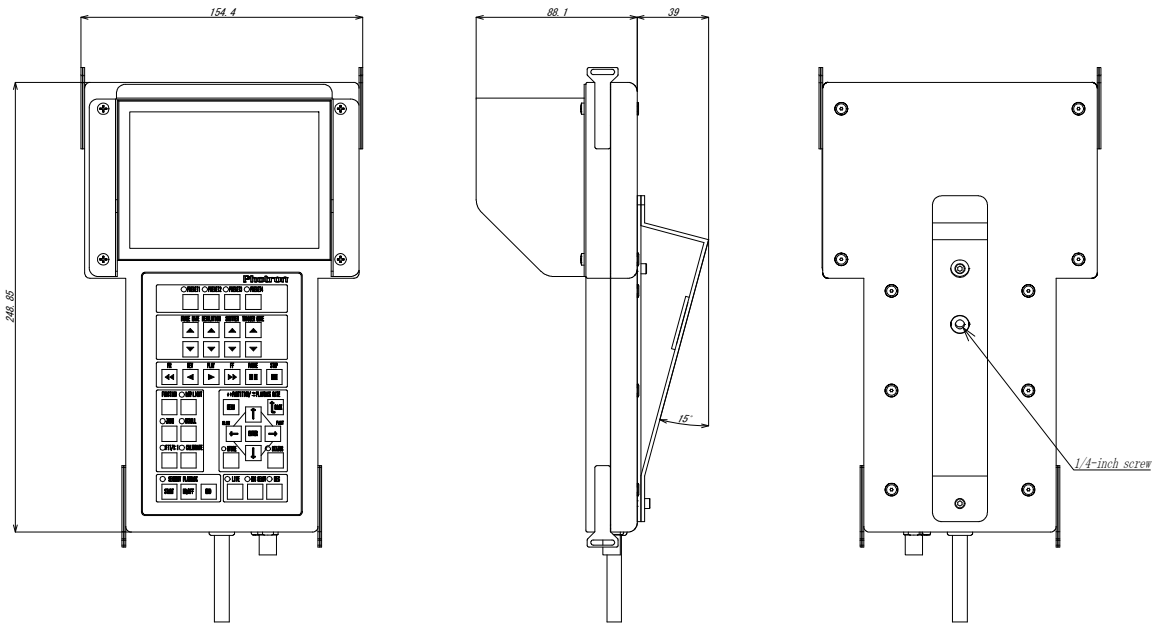

All dimensions are in millimeters

5.2.3. AC Power Supply Adapter

inches [mm]

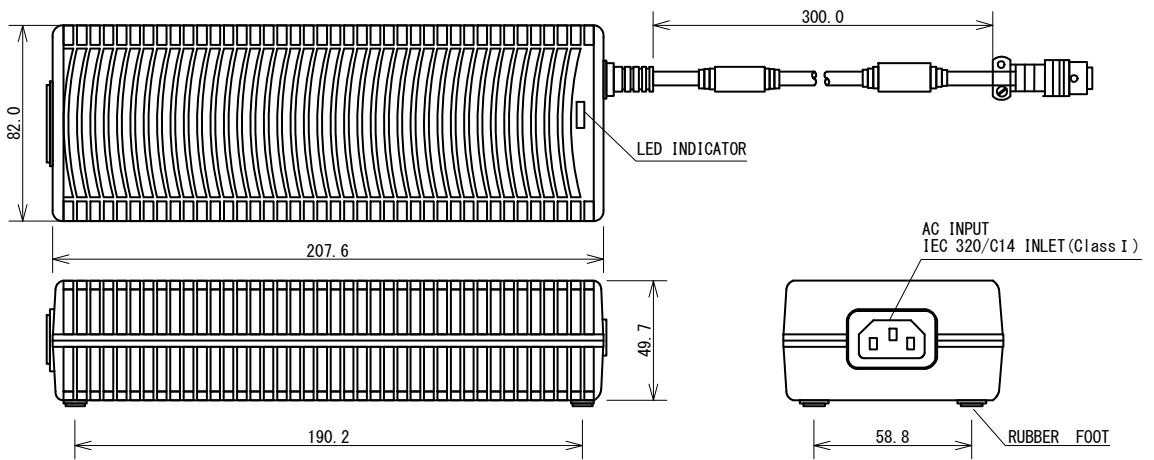

All dimensions are in millimeters

5.3. Cleaning the Filter



To prevent the buildup of heat, the system circulates air into the camera body with a fan. In order to lower the risk that dirt and dust in the air will enter the camera, the air vent and exhaust vent are fitted with filters. Clean the filters and the area around the filters regularly in order to keep the system in top condition.

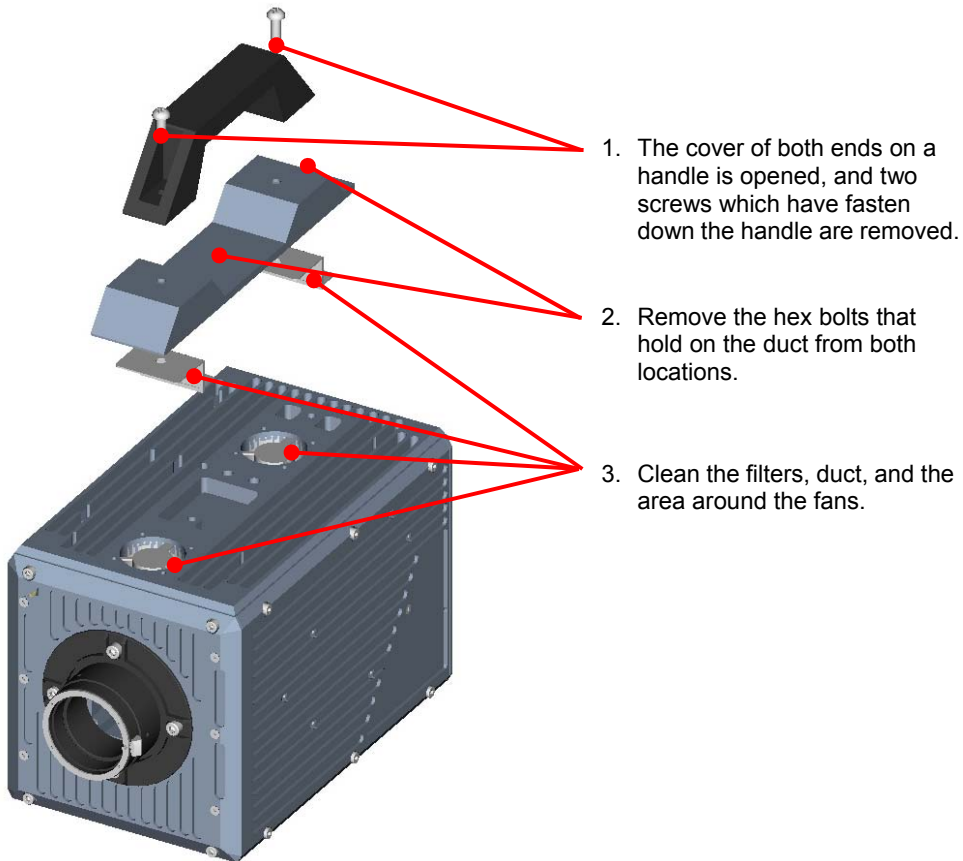

Do not remove any of the screws on the camera body except for the screws in the locations shown in the diagram above.



The risk of problems can be lowered by cleaning the filters. However, problems caused by the effects of heat from not cleaning the filters are exempted from warranty service, even if they occur during the system's warranty period.



The filters reduce the risk that dirt and dust will enter the camera body, but there is no guarantee that it will eliminate problems caused by dirt and dust.

Chapter. 6 **Warranty**

6.1. About the Warranty

6.1. About the Warranty

This system has been shipped having undergone rigorous testing. However, in the unlikely event that it malfunctions due to a manufacturing defect, it will be repaired, at no charge, within the warranty period.

◆ Warranty Exceptions

The following exceptions will result in fee-based repair, even within the warranty period.

1. Damage or malfunction as a result of fire, earthquake, water damage, lightning, other natural disasters, pollution, or the effects of abnormal voltage.
2. Damage or malfunction as a result of dropping or mishandling during shipment or when moving after purchase or misuse.
3. Consumable goods (cables)
4. When repair, adjustment, or alternation done by an entity other than Photron service has been performed on the system, or damage or malfunction that is determined to be attributed to a fault in the use the product.

For inquires related to malfunction, contact the dealer where the product was purchased, or the nearest Photron office.



Reference

- For inquires related to our product, refer to "7.1. Contact Information", page 88.

Chapter. 7 **Contacting Photron**

7.1. Contact Information

7.1. Contact Information

For inquires related to PFV, contact Photron at the contact information listed below. Additionally, the following items will be verified when inquiring, so please prepare them in advance.

Items Verified	Concrete Example
Contact Information	Company, school or organization name, customer contact name, contact phone number, contact e-mail.
Product Name	FASTCAM SA6 / SA6 RV
Serial Number	Check on the nameplate seal.
Condition of the system and what is known about it.	

Contact Information	
In Americas and Antipodes	<p>PHOTRON USA, INC. 9520 Padgett Street, Suite 110 San Diego, CA 92126-4426, USA Phone : 800-585-2129 or 858-684-3555 Fax : 858-684-3558 E-mail : image@photron.com www.photron.com</p>
In Europe, Africa and India	<p>PHOTRON EUROPE LIMITED The Barn, Bottom Road, West Wycombe, Buckinghamshire, HP14 4BS, U.K. Phone : +44(0) 1494 48 1011 Fax : +44(0) 1494 48 7011 E-mail : image@photron.com www.photron.com</p>
In other areas	<p>PHOTRON LIMITED Fujimi 1-1-8, Chiyoda-Ku Tokyo 102-0071, Japan Phone : +81 3 3238 2107 Fax : +81 3 3238 2109 E-mail : image@photron.co.jp www.photron.co.jp</p>

FASTCAM SA6
FASTCAM SA6 RV

Hardware Manual Revision 1.01E

Publication Date January, 2012
Publisher PHOTRON LIMITED
Chiyoda Fujimi Bldg., Fujimi 1-1-8, Chiyoda-ku,
Tokyo 102-0071, JAPAN