

# *FASTCAM BC2 HD*

## Hardware Manual

*Revision 1.03E*

**Photron**

- The copyright of this manual is held by PHTRON LIMITED.
- Product specifications and manual contents can change without advanced notification.
- This manual was created taking every possible measure to ensure the accuracy of its contents. However, if you find a section which is unclear, a mistake, or an omission, please contact PHTRON LIMITED using the contact information provided at the end of the manual.
- PHOTRON LIMITED is not responsible for the aftermath of the results of using the product or from following the instructions in this manual.

## Introduction

Thank you for your purchase of Photron's high-speed camera system, the "**FASTCAM BC2 HD**" (referred to below as the system).

This manual contains the operating instructions and warnings necessary for using the system.









Please read the entire manual before using the system.

If any part of this manual is unclear, contact Photron using the contact information printed at the back of the manual.

After you finish reading the manual, store it in a safe place along with the warranty card and refer back to it when necessary.

## Manual Notation

The following icons and symbols are used in the explanations in this manual.

Icon/symbol	Explanation
	This symbol indicates content that should always be read.
	This symbol indicates instructions to follow in the operation of the camera and items to be careful of.
	This symbol indicates items to be aware of when operating the camera and supplemental explanations.
	This symbol indicates a reference location.
	This symbol indicates a space to use for making memos.
	This symbol is used to indicate connectors.
	This symbol is used to indicate item names and reference locations.
	This symbol is used to indicate menu and submenu names.
	This symbol is used to indicate Remote controller keys (optional accessory).



# Using the Manual

---

This section explains the layout of the manual.

◆ Introduction

The introduction explains about the manual and safety precautions.

◆ Chapter 1. Overview

This chapter provides an overview of the product and an explanation of its features.

◆ Chapter 2. Setup

This chapter provides an overview of the components that make up the product.

◆ Chapter 3. Recording

This chapter explains operations related to recording.

◆ Chapter 4. Connecting a PC

This chapter explains the procedure for connecting the system to a PC. Refer to the "Photron FASTCAM Viewer User's Manual" for additional details on using a PC to control the system.

◆ Chapter 5. Product Specifications

This chapter explains the system's specifications.

◆ Chapter 6. Warranty

This chapter explains the warranty.

◆ Chapter 7. Contacting Photron

This chapter lists contact information to use when contacting Photron if the product malfunctions or if a portion of the manual is unclear.

## Using the Product Safely and Correctly

In order to prevent injury to yourself and others and to prevent damage to property, carefully observe the following safety precautions.

Photron has given its full attention to the safety of this product. However, the extent of damage and injury potentially caused by ignoring the content of the safety precautions and using the product incorrectly is explained next. Please pay careful attention to the content of the safety precautions when using the product.



Warning

This symbol indicates actions that carry the risk that a person could receive a serious injury.



Caution

This symbol indicates actions that carry the risk that a person could receive a moderate injury or that damage to physical property might occur.

◆ The safety precautions to observe are explained with the following symbols.



This symbol indicates actions that require caution.



This symbol indicates actions that are prohibited and must be avoided.



This symbol indicates actions that must always be performed.



## Warning



- Do not perform actions that will damage the AC cable or plug.

(Do not damage the cable, modify it, use it near a heater, excessively bend, twist or pull on it, place heavy objects on it, or bundle it.)

Using the cable when damaged can cause fire, electric shock, or a short circuit.



- Do not use the system in a manner which will exceed the rating of the power outlet or wiring equipment used.

Exceeding the power rating may cause a fire from excessive heat.



- Do not insert metallic objects inside, or pour liquids such as water on, the product.

Doing so can cause fire, electric shock, or malfunction from short circuit or heat.



- Do not disassemble or modify the product.

There are high voltages inside the product that can cause electric shock.



- Do not plug in or unplug the power cord with wet hands.

Doing so can cause electric shock.



- Make sure the power cable is fully inserted into the socket.

Not fully inserting the plug can cause fire from electric shock or heat.



- When something is wrong with the system, unplug the power cable immediately.

· When a foreign substance or liquid, such as metal or water, gets inside.

· When the outer case is broken or damaged, such as from a fall.

· When the system produces smoke, a strange smell, or strange sound.

Using the system in these conditions might cause a fire or electric shock.



## Caution



- Always unplug the system when cleaning it or when it is unused for a long period of time.  
Leaving or storing the product connected to the power source might cause fire from insulation deterioration or electrical discharge.



- Do not place the product in a location where the temperature gets unusually hot.  
The trunk and inside of a car can get especially hot in summer.  
Doing so can cause the outer case and internal components to deteriorate or cause a fire.



- Do not place the system in a location prone to oily smoke or steam, or in a location with a lot of humidity or dust.  
Oil, moisture, and dust conduct electricity, which can cause a fire or electric shock.



- Ambient temperature 0-40°C, humidity 85% RH or lower, maximum altitude 2000 m or lower, and no condensation.  
Using the system outside of these limits can cause malfunction.



- Do not store the equipment in a location where the temperature goes -20°C or lower or 60°C or higher.  
Also, keep condensation from forming inside the system.



- This device is for indoor use, do not use it outdoors.  
Do not use in a location that has dust.  
Using the system outside of these limits can cause malfunction.



- When shipping, remove the connecting cable and use the original packaging or a dedicated carrying case.  
Do not ship the equipment in an environment where the temperature goes -20°C or lower or 60°C or higher. Also, prevent condensation from forming during shipment.



## Cleaning the Image Sensor Surface

The image sensor can be destroyed by electrostatic discharge (ESD).  
Be aware of the following precautions when cleaning the image sensor's glass surface.



- Do not bring any tools without an antistatic treatment near the image sensor. Do not use such tools to clean the image sensor.
- Do not use static absorbing cleaning tools (such as antistatic brushes).



- Discharge any static electricity built up in your body before working.  
(Example: by touching grounded metal)
- For overall cleaning, lightly blow with anti-static dry, compressed air.

If the image sensor is particularly dirty, clean it by gently wiping it with high-purity IPA (isopropyl alcohol) and a synthetic cloth for semiconductors.

(The coating on the glass surface may come off if rubbed strongly.)

# Table of Contents

<b>1. Overview</b>	<b>1</b>
1.1. Product Overview and Features .....	2
<b>2. Setup</b>	<b>3</b>
2.1. System Components and Accessories .....	4
2.1.1. Components .....	4
2.1.2. Optional Accessories .....	4
2.2. Part Names .....	5
2.2.1. Camera body .....	5
2.2.2. Camera Body Part Names .....	6
2.2.3. Camera Body Rear Status Display LEDs .....	8
2.2.4. Interchangeable Lens Mounts .....	10
2.2.5. Remote controller (Optional Accessory) .....	11
2.2.6. RS-422 Serial Control .....	12
2.2.7. Power Supply Connector .....	13
2.3. Device Connections .....	14
2.3.1. Connecting a Video Monitor .....	14
2.3.2. Connecting the AC Power Supply Unit .....	15
2.3.3. Connecting the Remote controller (Optional Accessory) .....	16
2.3.4. Connecting a PC .....	17
<b>3. Recording</b>	<b>19</b>
3.1. Image Initialization (Calibration) .....	20
3.1.1. Executing Calibration .....	20
3.1.2. Saving Calibration Settings .....	20
3.1.3. Loading Calibration Settings .....	20
3.1.4. Calibration Mode .....	20
3.2. Selecting the Frame Rate .....	21
3.3. Selecting the Resolution .....	22
3.3.1. Resolution Lock .....	22
3.4. Selecting the Shutter Speed .....	23
3.4.1. Changing SHUTTER MODE .....	23
3.4.2. DS SHUTTER Setting .....	23
3.4.3. AUTO EXPOSURE Operation .....	24
3.5. Selecting the Trigger Mode .....	26
3.5.1. START Mode .....	26
3.5.2. CENTER Mode .....	26
3.5.3. END Mode .....	27
3.5.4. MANUAL Mode .....	27

3.5.5.	RANDOM Mode	27
3.5.6.	RANDOM RESET Mode	28
3.5.7.	RANDOM CENTER Mode	29
3.5.8.	RANDOM MANUAL Mode	30
3.6.	LOW LIGHT Mode	31
3.7.	VARIABLE Setting	31
3.8.	White Balance Adjustment	32
3.8.1.	Using Preset White Balance	32
3.8.2.	Using User White Balance	32
3.9.	Color Enhancement Function	33
3.10.	Look-Up Table (LUT)	33
3.10.1.	Using a Custom LUT	37
3.11.	Edge Enhancement Function	37
3.12.	Black Adjust Level	37
3.13.	Partition Memory & Record	38
3.14.	Input Signals	38
3.14.1.	TRIG SW IN Connector	38
3.14.2.	SYNC IN Connector	38
3.15.	Using External Triggers	39
3.15.1.	Inputting an External Trigger Signal	39
3.16.	Using External Synchronization Signals	40
3.16.1.	Inputting an External Synchronization Signal	40
3.16.2.	Synchronizing the System with Other External Devices (Frame Rate Synchronized Recording)	41
3.16.3.	Synchronizing the System with Other Cameras (Mixed Device Synchronized Recording)	44
3.17.	Signal Delay	45
3.18.	Using the Programmable Switch (USER SW)	46

## **4. Connecting a PC 49**

4.1.	Connecting the Gigabit Ethernet Interface to a PC	50
4.1.1.	Connecting the PC and a PC	51
4.1.2.	Setting the IP Address	51
4.1.3.	Using DHCP (Dynamic Host Configuration Protocol)	51
4.1.4.	Connecting Multiple Systems and a PC	52
4.1.5.	Gigabit Ethernet Interface Initialization	52
4.1.6.	Initializing the Camera's IP Address	52

## **5. Product Specifications 53**

5.1.	Specifications	54
5.1.1.	Product Specifications	54
5.1.2.	General Specifications	55
5.1.3.	Optional Accessories	56

5.1.4.	Frame Rate & Resolution .....	58
5.1.5.	Recordable Image Count/Resolution .....	60
5.1.6.	Shutter Speed List .....	61
5.1.7.	List of Frame Rates Selectable with the VARIABLE Setting .....	64
5.2.	Dimensions .....	65
5.2.1.	Camera Body.....	65
5.2.2.	Camera Body (With View Finder Mount) .....	66
5.2.3.	Remote controller (Optional Accessory).....	67
5.2.4.	AC Power Supply Adapter .....	68
5.2.5.	AC Power Supply Adapter (With AC Cord Anchor Case).....	69
5.3.	Cleaning the Filter.....	70

<b>6. Warranty</b>	<b>71</b>
--------------------	-----------

6.1.	About the Warranty .....	72
------	--------------------------	----

<b>7. Contacting Photron</b>	<b>73</b>
------------------------------	-----------

7.1.	Contacting Photron.....	74
------	-------------------------	----



# 1. Overview

---

## 1.1. Product Overview and Features

## 1.1. Product Overview and Features

---

The FASTCAM BC2 HD demonstrates its versatility in creating video content to make broadcast programming even more entertaining by capturing decisive moments in sports such as baseball, soccer, swimming, and motorsports, or by recording various types of events in variety, science, and educational programs.

You can also create movies and commercials that leave an even greater impression on your audience by giving them attractive scene transitions.

For recording performance, the system can record at a maximum resolution of 2,048 x 2,048 pixels, 1,080 fps at the full frame resolution, and 2,000 fps at the full high definition resolution of 1,920 x 1,080 pixels. Now you can capture various events in unprecedented high resolution video. But not only high resolution video, the camera also features outstanding recording performance in the high speed range with a maximum frame rate of 86,400 fps.

Video can be output in HD SDI, so not only can it be recorded to tape or disk recorder, it can also be used directly on-air for a live broadcast.

The camera can be operated in two ways, via the Remote controller (optional accessory) or by using the PC software over a Gigabit Ethernet connection, so you can operate it in the desired manner depending on the conditions and scene.

The system is the combination of the pursuit of both recording performance and operability: a high speed camera that anyone can easily use. Use the state-of-the-art technology in the FASTCAM BC2 HD to slow down and observe high-speed phenomena or as an input component for a dynamic image measurement system. This manual explains the procedures for operating the system.



### Supplement

- This picture shows the state that option accessory is assembled.

## **2. Setup**

---

**2.1. System Components and Accessories**

**2.2. Part Names**

**2.3. Device Connections**

## 2.1. System Components and Accessories

---

### 2.1.1. Components

The system's standard components are listed below. Remove each component from the packaging and check it.

1.	Camera body	1
2.	AC power supply unit/AC cable	1
3.	Hexagonal lens mount adapter wrench (1.5 mm, 2 mm, 3 mm, 4 mm)	1 each
4.	Lens mount cap (camera integrated)	1
5.	FASTCAM Series Setup Disk (driver/application CD)	1
6.	FASTCAM BC2 HD Hardware Manual (this manual)	1
7.	Photron FASTCAM Viewer User's Manual	1
8.	Making a Gigabit Ethernet Connection (simple procedure manual)	1
9.	Gigabit Ethernet interface cable (LAN cable)	1

### 2.1.2. Optional Accessories

The following optional accessories are available for the system.

1. Remote controller
2. C mount kit
3. PL mount kit (normal type/shim type)
4. B4 mount kit
5. EF mount kit (normal type/remote type)
6. 4 output trigger box
7. Dedicated carrying case
8. Spare power supply connector (for creating a custom cable)
9. Dust-proof LAN connector cover
10. External battery cable
11. View finder relay box
12. View finder mount
13. Tripod adapter
14. Monitor pan head set
15. AC cord anchor case

---

## 2.2. Part Names

The system is composed of components including the camera body, AC power supply unit, and the "Photron FASTCAM Viewer" control software (referred to below as PFV).



For the system's camera body, AC power supply unit:

- Do not expose to a shock outside of specifications.
- Do not use in an area with flammable gas or dust present.
- Do not place on an unstable location such as on a wobbly platform or an incline.
- Do not disassemble or modify.
- Do not expose to liquids such as water.
- Do not use in a manner where excessive force is applied.

### 2.2.1. Camera body

The camera body contains IC memory for recording images and has been designed with the capability to save high-speed images as uncompressed digital data. The back of camera body has an HD SDI video output connectors that can playback recorded images on a video monitor, a Gigabit Ethernet interface to connect to a PC to fully control the camera or download data, and input connectors for synchronization/trigger signals.



**Camera Body Exterior**



**Camera Body Rear**

2.2.2. Camera Body Part Names

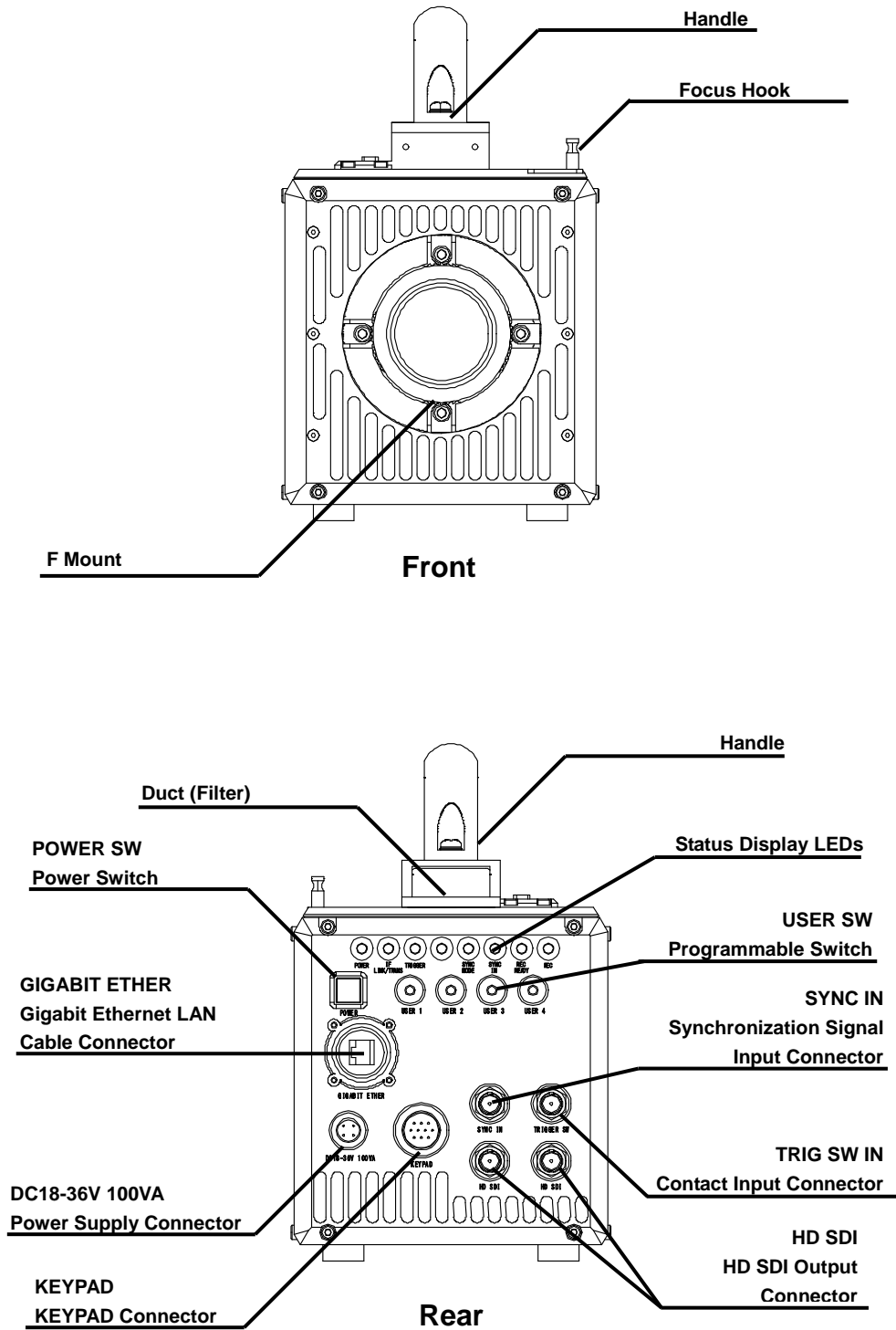

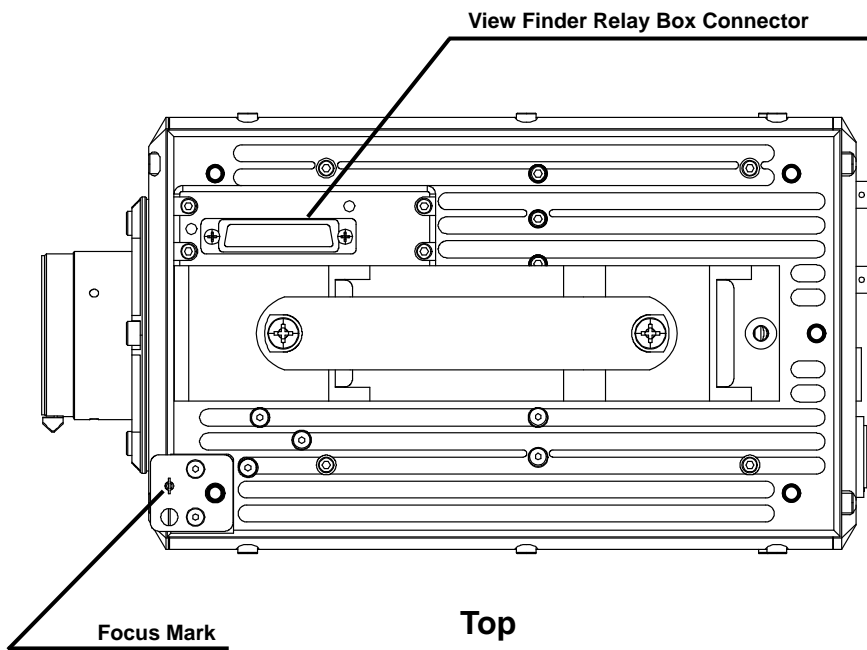

### 2.2.3. Camera Body Rear Status Display LEDs

There are a number of LEDs on the rear of the system's camera body. These LEDs indicate the status of the system. The meaning of each LED is explained here.



- **POWER (Green)**  
LED ON: Power on  
LED OFF: Power off
  
- **IF LINK/TRANS (Red)**  
LED ON: The Gigabit Ethernet interface is connected  
LED FLASHING: Transferring data  
LED OFF: The Gigabit Ethernet interface is not connected
  
- **TRIGGER (Yellow)**  
LED ON: A trigger signal has been input (illuminates for 0.1 s when the trigger signal is input)  
LED OFF: A trigger signal has not been input
  
- **SYNC MODE (Red)**  
LED ON: In external synchronization mode  
LED OFF: In internal synchronization mode
  
- **SYNC IN (Yellow)**  
LED ON: A synchronization signal is being input  
LED OFF: A synchronization signal is not being input
  
- **REC READY (Yellow)**  
LED ON: Ready to record  
LED FLASHING: ENDLESS recording ("REC" LED also simultaneously flashes)  
LED OFF: Not ready to record
  
- **REC (Red)**  
LED ON: Random mode ready state  
LED FLASHING: Recording  
LED OFF: Not recording

---

◆ LED illumination/flashing in operational states

■ During low light mode operation

The LEDs other than POWER (green) and IF LINK/TRANS (red) flash at a regular interval.

■ When calibration is run from USER SW or the Remote controller

The LEDs other than POWER (green) and IF LINK/TRANS (red) flash alternately from right to left three times and from left to right three times.

■ During the Gigabit Ethernet interface initialization

The LEDs other than POWER (green) and IF LINK/TRANS (red) flash alternately from right to left and from left to right a number of times.



Reference

- For how to initialize the Gigabit Ethernet interface, see "4.1.5 Gigabit Ethernet Interface Initialization", page 52.

### 2.2.4. Interchangeable Lens Mounts

The camera's lens mount can be changed according to the recording application.

There are five types of interchangeable lens mounts: the Nikon F mount, C mount (optional accessory), PL mount (optional accessory), B4 mount (optional accessory), and EF mount (optional accessory).

◆ How to change lens mounts (Example: Nikon F mount → PL mount)

- ① Remove the four M5 hexagonal socket bolts with the hexagonal wrench.
- ② Remove the Nikon F mount portion as a whole unit.
- ③ Attach the PL mount unit with the hexagonal socket bolts.
- ④ After attaching the unit, always check to ensure it is not loose or rattles.

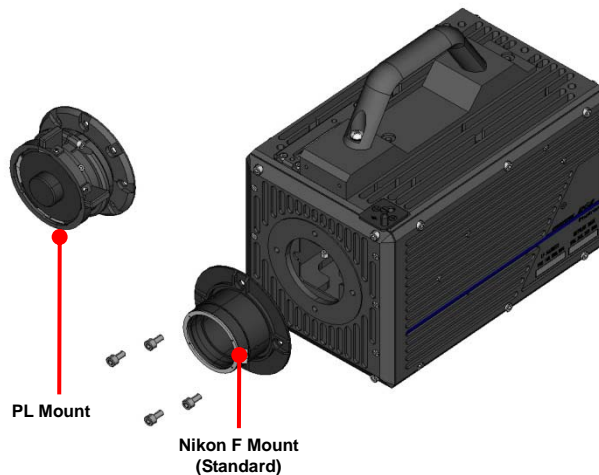

**! Caution**

- When using the C mount or B4 mount, clipping may occur around the edge of the video.

## 2.2.5. Remote controller (Optional Accessory)

The system can be operated while checking a monitor by connecting the optional Remote controller to the [KEYPAD] connector on the rear of the camera body. The Remote controller is also hot-pluggable, it can be plugged into and unplugged from the camera while the power is on.



Camera body connector name	Signal	Camera body connector model name (manufacturer)	Remote controller connector model name (manufacturer)
KEYPAD	Keypad signal	PT02A-12-10S (023) (Amphenol)	PT06A-12-10P (023) (Amphenol)

### Supplement

- The Remote controller is an optional accessory. It is not included in the standard configuration.

### Reference

- For how to operate the Remote controller, refer to the "Remote controller User's Manual".

2.2.6. RS-422 Serial Control

The system supports operation with serial control via an RS-422 connection through the [KEYPAD] connector.

By setting the [STATUS OUT] menu to ON, the system status can be output via the serial connection. Check the command list for details.

A cable is not offered as an accessory. When using RS-422 control, construct a cable using the pin diagram below for reference.

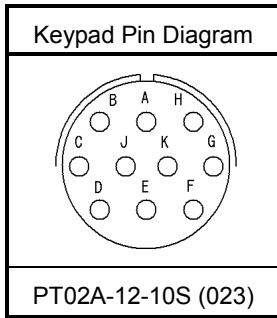

Connector name	Signal	Pin no.	Camera body connector model name (manufacturer)	Cable connector model name (manufacturer)	Input connector
KEYPAD	+12V OUT	A	PT02A-12-10S (023) (Amphenol)	PT06A-12-10P (023) (Amphenol)	Not specified
	SIGNAL GND	B			
	RXD+	C			
	RXD-	D			
	TRIGGER SW	E			
	TXD-	F			
	TXD+	G			
	POWER GND	H			
	NC	J			
	NC	K			



When using the connector pins directly, refer to the chart above and ensure the wiring is correct. Incorrect wiring can cause malfunction.



The voltage on pin A (+12V OUT) is used to power the Remote controller, do not use it for other purposes.

**Reference**

- For inquiries related to RS-422 serial control, see "7.1 Contacting Photron", page 74.

**Supplement**

- Serial control commands are available as separate list of commands. Please contact Photron or the dealer where the system was purchased regarding the command list.

## 2.2.7. Power Supply Connector

This connector is used to input the DC power supply. Connect the supplied AC adapter or the optional IDX battery cable (battery sold separately) to this connector.

The connector for the cable is available as an optional accessory. When using other power supplies, construct a cable using the pin diagram below for reference.

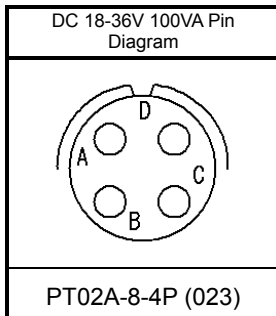

Connector name	Signal	Pin no.	Camera body connector model name (manufacturer)	Cable connector model name (manufacturer)
DC18-36V 100VA	+18V to +36V IN	A	PT02A-8-4P (023) (Amphenol)	PT06A-8-4S (424) (Amphenol)
	POWER GND	B		
	POWER GND	C		
	+18V to +36V IN	D		



### Warning

When using the connector pins directly, refer to the chart above and ensure the wiring is correct.

If the wiring is incorrect, not only is there the danger of the system malfunctioning, but also of fire and electric shock.



### Warning

Do not use a power supply which does not meet the system's specifications or a power supply that is not guaranteed to be safe.

By using a power supply outside of the system specifications, there is not only the danger of the system malfunctioning, but also of fire and electric shock.

## 2.3. Device Connections

### 2.3.1. Connecting a Video Monitor

A video monitor connected to the camera can be used to check the live image (camera pass-through image). Connect the video input connector according to the display monitor's video signal type to the [HD SDI] OUT connector on the rear of the camera body with a BNC cable.

HD SDI's support formats are listed in the chart below.

NTSC setting	1080i	60Hz , 59.94Hz
	1080p	30Hz , 29.97Hz , 24Hz , 23.98Hz , 24Hz(sF) , 23.98Hz(sF)
PAL setting	1080i	50Hz
	1080p	25Hz , 24Hz , 23.98Hz , 24Hz(sF) , 23.98Hz(sF)

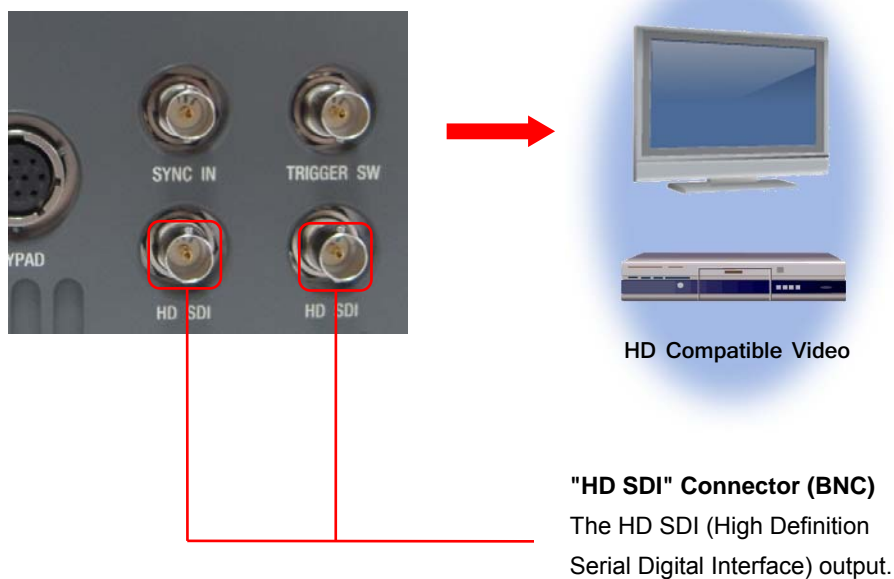

#### Supplement

- Use 5C-FB compliant cables for HD-SDI output.

---

### 2.3.2. Connecting the AC Power Supply Unit

Connect the supplied AC power supply unit to the power supply.



- ① Connect the AC power supply unit to the [DC18-36V 100VA] connector on the rear of the camera body.
- ② Connect the AC cable to the AC power supply unit.
- ③ Connect the AC cable to the power outlet.

#### Reference

- For power supplies that can be used, see "DC Power Supply" in "5.1.2 General Specifications", page 55.

### 2.3.3. Connecting the Remote controller (Optional Accessory)

If you have the optional Remote controller, connect it by plugging one end of the cable included with the Remote controller in the connector labeled [KEYPAD] on the rear of the camera body and the other end in the connector (15 pin) on the right side of the Remote controller.



#### Supplement

- The Remote controller is hot-pluggable. It can be plugged in and unplugged while the system's power is on.

#### Reference

- For how to operate the Remote controller, refer to the "Remote controller User's Manual".

---

### 2.3.4. Connecting a PC

The system can be controlled from a PC using the Gigabit Ethernet interface. This section explains the required setup when connecting the system to a PC.



To connect a PC to the system, connect the system to a commercially available 1000BASE-T-compatible interface board with a LAN cable. For the LAN cable, prepare a UTP or STP Cat 5e (enhanced category 5) or higher LAN cable (UTP: unshielded, STP: shielded).

The maximum cable length between the PC and the system is, compliant to the 1000BASE-T specification, up to 100 m. One PC can connect to a maximum of 64 Photron Gigabit Ethernet interface equipped cameras using a hub. When connecting multiple devices, connect them through a switching hub that can connect at 1000BASE-T. The maximum length of the cable that connects the system (or PC) to the switching hub is also 100 m.

#### Reference

- For how to operate the Photron FASTCAM Viewer software, refer to the "Photron FASTCAM Viewer User's Manual".

## 2. Setup

---



# **3. Recording**

---

- 3.1. Image Initialization (Calibration)**
- 3.2. Selecting the Frame Rate**
- 3.3. Selecting the Resolution**
- 3.4. Selecting the Shutter Speed**
- 3.5. Selecting the Trigger Mode**
- 3.6. LOW LIGHT Mode**
- 3.7. VARIABLE Setting**
- 3.8. White Balance Adjustment**
- 3.9. Color Enhancement Function**
- 3.10. Look-Up Table(LUT)**
- 3.11. Edge Enhancement Function**
- 3.12. Black Adjust Level**
- 3.13. Partition Memory & Record**
- 3.14. Input Signals**
- 3.15. Using External Triggers**
- 3.16. Using External Synchronization Signals**
- 3.17. Signal Delay**
- 3.18. Using the Programmable Switch (USER SW)**

### 3.1. Image Initialization (Calibration)

---

In order to maximize the high image quality of the system, it is necessary to correct the non-uniformity in each pixel that is inherent in the image sensor.

For this product, an output correction of each pixel on the image sensor is adopted. Therefore, a faithful image output can be obtained corresponding to the light input.

#### Important

- In order to obtain faithful image output, it is highly recommended to execute calibration before recording when the following settings are changed.

- When the frame rate is changed
- When the shutter speed is changed
- When the resolution is changed

Also, depending on the settings, the following phenomena may occur.

- Fixed noise like horizontal bands appears
- A portion of the screen is clear, but noise appears in the area around it

These phenomena can be resolved by executing calibration again.

#### 3.1.1. Executing Calibration

Calibration is executed from the Remote controller (optional accessory) or from PFV.

#### Reference

- For how to execute the calibration procedure, refer to the "Remote controller User's Manual" or the "Photron FASTCAM Viewer User's Manual".

#### 3.1.2. Saving Calibration Settings

The black image data for correction that was obtained by executing calibration can be saved as one pattern internally on the system.

#### 3.1.3. Loading Calibration Settings

The black image data for correction saved internally can also be loaded.

#### 3.1.4. Calibration Mode

For this product, the calibration method can be changed by user. A NORMAL method and a FINE method can be used.

---

## 3.2. Selecting the Frame Rate

With the system, you can record images from 60 (50) to 1,080 fps using the full 2,048 x 2,048 pixel resolution of the image sensor. For frame rates faster than 1,080 fps, high-speed photography is achieved by limiting the read area of the image sensor.

### Supplement

- The minimum frame rate in NTSC mode is 60 fps.
- The minimum frame rate in PAL mode is 50 fps.

### Reference

- For frame rates faster than 1,080 fps, the resolution is automatically set to the maximum available at that frame rate. For more details, see "5.1.4 Frame Rate & Resolution", page 58.

### 3.3. Selecting the Resolution

---

With the system, you can record images with a maximum size of 4,194,304 pixels using the high-speed image sensor, which has a maximum size of 2,048 x 2,048 pixels. You can also record at even faster frame rates or reduce the amount of image data to make even longer recordings by limiting the resolution according to the application.

#### Caution

- The recording time when the horizontal resolution is set to 1,920 is the same as when the horizontal resolution is 2,048.  
Example: The recording time is the same for a 2,048 x 1,536 pixels resolution and a 1,920 x 1,536 pixels resolution.

#### Reference

- For more information on the relationship between frame rate and resolution, see "5.1.4 Frame Rate & Resolution", page 58.

#### 3.3.1. Resolution Lock

Generally, a max resolution under respective FPS will be set automatically when the FPS is changed. Under the circumstance of using a Resolution Lock function, the speed can be changed while resolution is fixed to a certain value.

#### Caution

- When using a Resolution Lock function, if a resolution that does not compatible with the specified FPS is selected, a max resolution under the specified speed will be set automatically instead.

---

## 3.4. Selecting the Shutter Speed

---

The shutter speed is independent of the frame rate, so you can control the exposure time in one frame using the electric shutter. By making an exposure that is of a shorter period than the frame rate, high-speed objects can be recorded blur-free.

The shutter speed can be set from 1/frame s to a maximum of 1/367,000 s (approximately 2.76  $\mu$ s).

The shutter speed display can be switched between "1/xxx S" and "0.xxx S".

### Caution

- The numerical value of "0.xxx S" is the actual exposure time.  
The numerical value of "1/xxx S" is a round figure. It differs slightly from the actual exposure time.

### Reference

- For more details about the shutter speed, see "5.1.6 Shutter Speed List", page 61.

### 3.4.1. Changing SHUTTER MODE

By switching between [MODE1] and [MODE2] on the [SHUTTER MODE] submenu on the [SHUTTER] menu, the shutter speed value first used when the frame rate is changed can be set.

**MODE1:** Changing the frame rate automatically sets the shutter speed to 1/frame s.

**MODE2:** Changing the frame rate does not change the shutter speed, it maintains the current setting.

### 3.4.2. DS SHUTTER Setting

DS SHUTTER is a mode that records the high brightness portion and low brightness portion in one image at the same time by adjusting the light exposure internally in the sensor. By using this function, when recording a subject with an extremely large difference in the brightness in the image, the sensor functions so that it can record at the proper light exposure for both the high brightness and low brightness portions.

The light exposure adjustment can be set from 0% to 95% in 5% increments according to the difference in brightness of the subject.

### Caution

- This function cannot be used with the operations below.
  - When the AUTO EXPOSURE function is used
  - When the trigger mode is RANDOM RESET
- When using the DS SHUTTER function on color models, there may be situations where the colors are unbalanced and the color reproducibility degrades.

### Supplement

- The adjustment amount is expressed as %. For the adjustment strength, 0% is no adjustment, 95% is the maximum effect.

### 3.4.3. AUTO EXPOSURE Operation

The system has a function that automatically varies the shutter (the sensor's exposure time) for the quantity of light input so that it will achieve the desired image output level.

After the settings are made once, this function displays its effect when recording in an environment where the subject's amount of light changes.

When using this function the following four items must be set in advance.

"AREA", "TARGET\_VALUE", "RANGE", "SHUTTER"

Each of these settings is explained below.

◆ AREA

Sets the image area.

The AUTO EXPOSURE function operates so that the average value of the image output level in the area specified here becomes the desired image output level.

◆ TARGET VALUE

Sets the desired image output level. Set this value as a 10-bit gradation (0-1023).

◆ RANGE

Gives the desired image output level a range. Set this value as a 10-bit gradation (0-1023).

The AUTO EXPOSURE function changes the shutter so that the average value of the image output level in the range specified by AREA is in the range of "TARGET\_VALUE ± RANGE".

◆ SHUTTER

Sets the maximum exposure time. Set in order to prevent subject blur from an exposure time that is too long.

 Important

- The AUTO EXPOSURE function maintains a constant image brightness by varying the shutter speed (sensor's exposure time).  
Therefore, the image may deteriorate as the shutter speed varies from the calibrated setting when using this function.  
For details, see "3.1 Image Initialization (Calibration)", page 20.



## Important

- When the AUTO EXPOSURE function is operating, the camera will not operate the shutter with an exposure time longer than the shutter value set here.

These settings are shown in the diagram below.

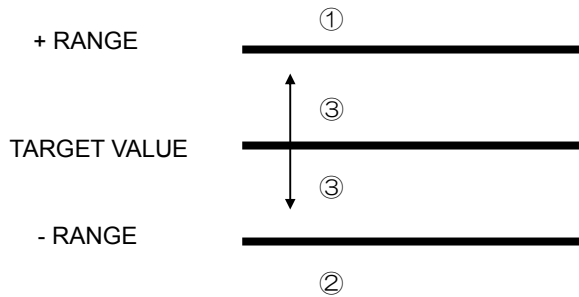

If the image level being output (the average value of the area set with AREA) is □, □, or □, the function operates as below.

◆ For position □

Since the image level being output is higher than the range  $TARGET\ VALUE \pm RANGE$ , the function operates to close the shutter (shorten the exposure time).

◆ For position □

Since the image level being output is lower than the range  $TARGET\ VALUE \pm RANGE$ , the function operates to open the shutter (lengthen the exposure time).

◆ For position □

Since the image level being output is within the range of  $TARGET\ VALUE \pm RANGE$ , the operation of the shutter is not varied.

- The DS SHUTTER function is inactive while the AUTO EXPOSURE function is being used.
- When the RANGE setting is a small value, the range of the desired image output level narrows.

- If the RANGE value is made smaller than necessary, placing the image level in the desired □ position is difficult.

In this case, the variable shutter operation cannot place the image level in the desired □ position and a phenomenon occurs where the image output level is unstable.

When a situation like this occurs, it can be resolved by making RANGE a larger value.

### 3.5. Selecting the Trigger Mode

In order to reliably capture high-speed phenomena with the system, many kinds of trigger modes have been made available. These trigger modes are explained next.

There are eight types of trigger modes listed below.

START	CENTER	END
MANUAL	RANDOM	RANDOM RESET
RANDOM CENTER	RANDOM MANUAL	

#### 3.5.1. START Mode

START mode is a trigger mode where recording starts the instant the trigger is input, the scene is recorded until the memory is full, and then recording ends. This mode is suitable for taking images of high-speed phenomena when what will happen, and when it happens, is known in advance.

For example, in a situation with a maximum useable memory of two seconds for recording, two seconds of high-speed video is saved immediately after the trigger is input.



#### 3.5.2. CENTER Mode

CENTER mode is a trigger mode where an equal amount of content recorded before and after the trigger is input is saved to memory. This mode is suitable for viewing before and after an important instant. For example, in a situation with a maximum useable memory of two seconds for recording, one second before and one second after the trigger was input is recorded for a total of two seconds of high-speed video.

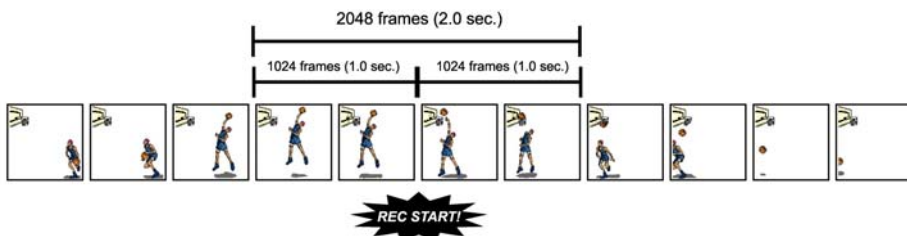

### 3.5.3. END Mode

END mode is a trigger mode where the content recorded immediately before the trigger is input is saved to memory. This mode is suitable for recording a high-speed phenomenon where it is hard to predict when the important action will start and stop. For example, in a situation with a maximum useable memory of two seconds for recording, the two seconds of high-speed video immediately before when the trigger was input are saved.



### 3.5.4. MANUAL Mode

MANUAL mode is a trigger mode, similar to CENTER mode, where the content recorded before and after the trigger is input is saved to memory, but the proportion of time before and after the trigger can be set as required. For example, in a situation with a maximum useable memory of two seconds for recording, 0.5 seconds before and 1.5 seconds after the trigger is input are recorded and saved, a total of two seconds of high-speed video.

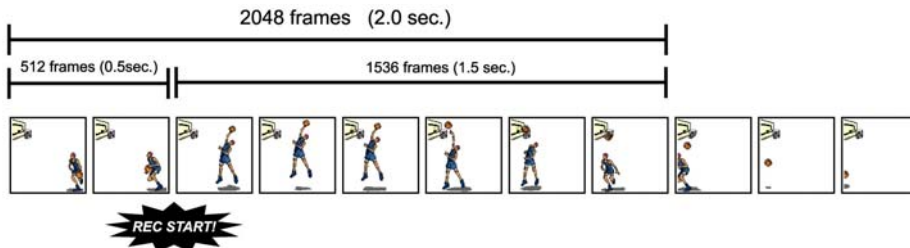

### 3.5.5. RANDOM Mode

RANDOM mode is a trigger mode where each time a trigger is input only a predetermined number of frames are saved to memory. For example, this function is convenient for a subject which is an irregular and repeated phenomenon which can have trigger output produced for each cycle or occurrence. The number of frames recorded each time the trigger is input can be set as desired, in one frame increments, from one frame to the maximum of all the recordable frames available.

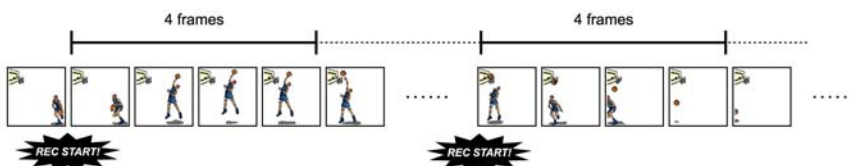

### 3.5.6. RANDOM RESET Mode

RANDOM RESET mode is explained here by comparing its operation with the normal mode.

RANDOM RESET mode is a mode to improve the temporal accuracy of the record start timing and the timing of the trigger input, where, to put it simply, with the input of the trigger signal, at the timing that it is input, the camera's record timing is reset.

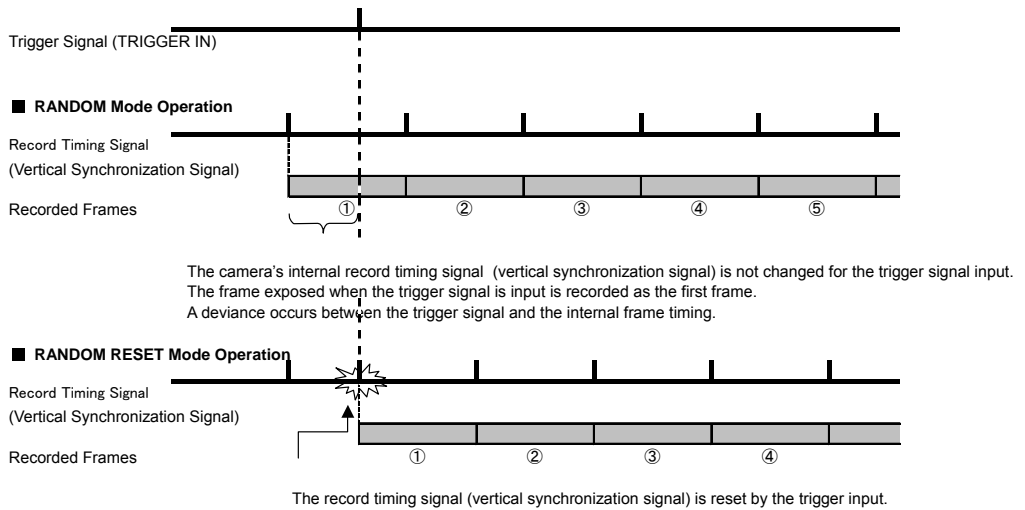

The diagram above illustrates the recording operation (timing) difference for the trigger input when the camera is set to normal RANDOM mode (START mode is the same) and RANDOM RESET mode.

In normal RANDOM and START mode, the camera starts recording when the trigger is input, but the internal record timing signal is independent and it operates regardless of when the trigger is input. For this reason, there may be situations where the exposure start time of the first frame when the trigger is input is advanced almost a full frame. The range of this overlap also cannot be known.

On the other hand, in RANDOM RESET mode, the camera's internal record timing signal is reset by the trigger input and exposure starts anew. For this reason, the trigger input time and the timing of the start point of the first frame are constant. The interval from when the trigger is input until the exposure begins is approximately 22.1  $\mu$ sec.

### 3.5.7. RANDOM CENTER Mode

RANDOM CENTER mode is a trigger mode, similar to RANDOM mode, where each time a trigger is input only a predetermined number of frames are saved to memory. The difference between this mode and RANDOM mode is that in RANDOM mode the number of specified frames are recorded directly after the trigger signal, whereas in RANDOM CENTER mode, at the timing of the trigger signal, the frames before and after the trigger are left in the recording memory. For example, this function is convenient for a subject which is an irregular and repeated phenomenon which can have a trigger output produced for each cycle or occurrence, and you want to check the action before and after the trigger timing. The number of frames recorded each time the trigger is input can be set as desired, in one frame increments, from one frame to the maximum of all the recordable frames available.

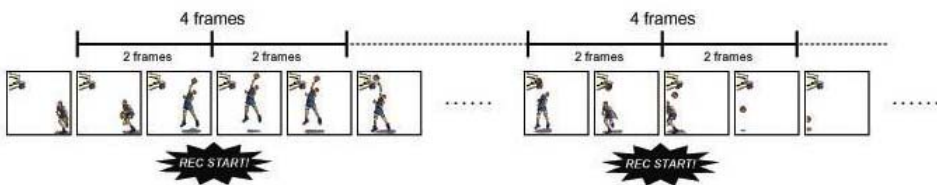

#### ◆ Setting the RANDOM CENTER mode frame count

Setting the frame count in RANDOM CENTER mode is the same as setting the frame count for RANDOM mode.

#### Reference

- For how to configure this mode, see "3.5.5 RANDOM Mode", page 27.

#### ◆ Setting the RANDOM CENTER mode record count

The number of trigger inputs that can be accepted in RANDOM CENTER mode is a maximum of 10. Set the number of trigger inputs in advance and the recording operation can be ended when that amount of trigger inputs has finished.

### 3.5.8. RANDOM MANUAL Mode

RANDOM MANUAL mode is a trigger mode, similar to RANDOM mode, where each time a trigger is input only a predetermined number of frames are saved to memory. The difference between this mode and RANDOM mode is that in RANDOM mode the number of specified frames are recorded directly after the trigger input, whereas in RANDOM MANUAL mode, at the timing of the trigger input, the frames before and after the trigger, each specified as desired, remain in the recording memory. For example, this function is convenient for a subject which is an irregular and repeated phenomenon which can have a trigger output produced for each cycle or occurrence, and you want to check the action before and after the trigger timing. The number of frames recorded each time the trigger is input can be set as desired, in one frame increments, from one frame to the maximum of all the recordable frames available.

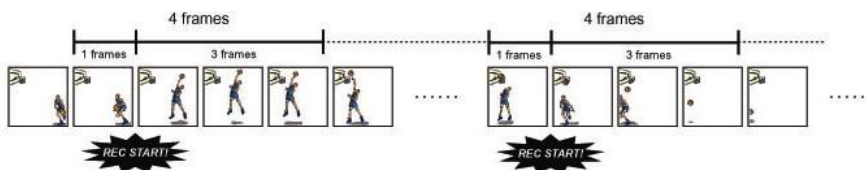

#### ◆ Setting the RANDOM MANUAL mode record count

Setting the record count in RANDOM MANUAL mode is the same as setting the record count for RANDOM CENTER mode.

#### Reference

- For how to configure this mode, see "3.5.5 RANDOM Mode", page 27.

#### ◆ Setting the RANDOM MANUAL mode frame count

To use RANDOM MANUAL mode, the proportion of frames to record before and after the trigger must be set in advance before recording.

---

### 3.6. LOW LIGHT Mode

The more you increase the frame rate or shutter speed of the camera, the less light enters the camera making the displayed image darker. Low light mode is a function that temporarily increases the exposure time, making the displayed image easier to see to enable you to focus and setup the camera.

### 3.7. VARIABLE Setting

In the recording conditions settings, the frame rate and resolution can be set to the desired value following the conditions listed below.

- FRAMERATE can be set to 102 types of frame rates from between 60 fps (50 fps) to 86,400 fps.  
The value inside parentheses is when set to PAL.
- The size and horizontal position of the resolution can be set in 256 (horizontal) and 32 (vertical) increments.

#### Supplement

- The recording time when the horizontal resolution is set to 1,920 is the same as when the horizontal resolution is 2,048.

Example: The recording time is the same for a 2,048 x 1,536 pixels resolution and a 1,920 x 1,536 pixels resolution.

## **3.8. White Balance Adjustment**

---

In digital video cameras, photographing white as pure white is described as "having the appropriate white balance". In the system's color models as well, in order to record with the correct color representation, the white balance must be adjusted for the color temperature of the light source used. The intensity of each color, R, G, and B, can be adjusted in this system. By adjusting the balance of those three colors to match the light source used, the appropriate white balance can be achieved.

Two methods are available for adjusting the white balance, preset and user-editable white balance. These methods are explained in this section.

### 3.8.1. Using Preset White Balance

This system has two types of white balance presets (5100K, 3100K) for use with common light sources. The suggested color temperature for these presets is listed below.

- 5100K (daylight, outdoors)
- 3100K (halogen light source)

### 3.8.2. Using User White Balance

User white balance can be set in order to achieve the most appropriate white balance for the light source used with the system and the conditions during recording.

The values set here are stored in the camera body's internal memory as the user preset, and they can be loaded by selecting "USER".

There are also two methods for setting user white balance, "AUTO USER" and "EDIT USER".

---

## 3.9. Color Enhancement Function

---

Color models feature an image color enhancement setting. The image color enhancement level can be adjusted in five steps, including the OFF setting.

### 3.10. Look-Up Table (LUT)

---

The LUT (look-up table) refers to a reference table that defines the relationship between the pixel brightness gradation of the original image data taken and the brightness gradation displayed on a PC or video monitor.

The system contains a hardware LUT function. You can display the image data taken with improved contrast (light and dark sharpness) or make an object in the image stand out by emphasizing a specified gray level range.

The LUT on the system and the relationship between video output and the PC software is explained in this section.

#### Caution

- When an image is saved with its brightness converted with the look-up table, the image saved is the image that has had its brightness converted.

### 3. Recording

---

◆ D1: Gain 1x

The input is always linear display. This LUT is used for normal conditions.

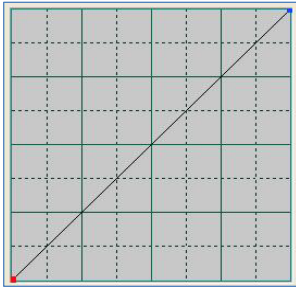

◆ D2: Gain 2x

The gain is doubled and you can display the dark areas of the image emphasized.

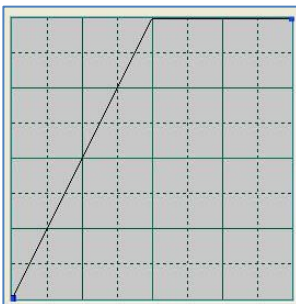

◆ D3: Gain 4x

The gain is quadrupled and you can display the dark areas of the image emphasized. This LUT emphasizes the dark portions even more than D2.

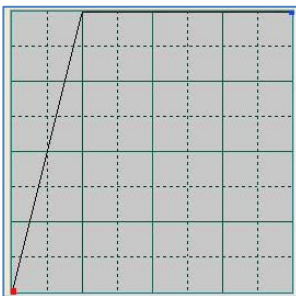

---

◆ D4: Gamma 0.56

This LUT is 0.56 gamma correction. The optimum Gamma for a MAC monitor.

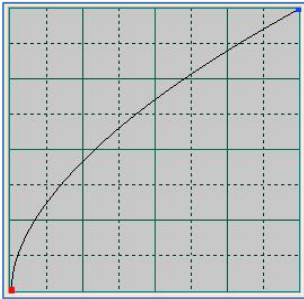

◆ D5: Gamma 0.56 Gain 2x

A LUT of doubled GAIN at Gamma 0.56.

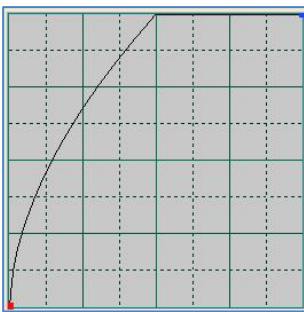

◆ D6: Gamma 0.56 Gain 4x

A LUT of quadrupled GAIN at Gamma 0.56.

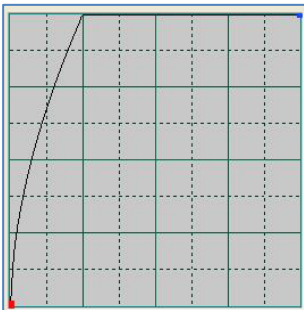

### 3. Recording

---

◆ D7: Gamma 0.45

This LUT is 0.45 gamma correction. The optimum Gamma for a video monitor.

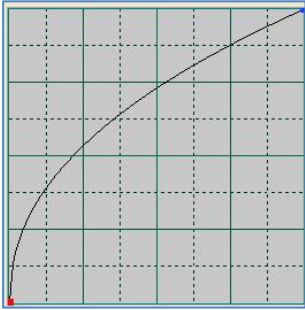

◆ D8: Gamma 0.45 Gain 2x

A LUT of doubled GAIN at Gamma 0.45.

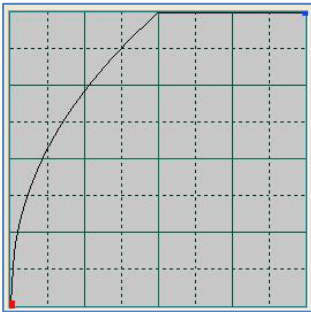

◆ D9: Gamma 0.45 Gain 4x

A LUT of quadrupled GAIN at Gamma 0.45.

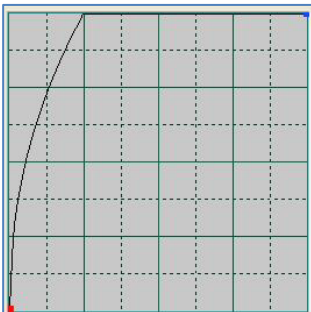

---

### 3.10.1. Using a Custom LUT

Creating a LUT pattern is done with PFV.

#### Reference

- For how to create a LUT pattern, refer to the "Photron FASTCAM Viewer User's Manual".

## 3.11. **Edge Enhancement Function**

---

With the system's edge enhancement setting, you can enhance the edges in the recorded image in three steps.

Menu display	Contents
OFF	Edge enhancement off.
LEVEL 1	Edge enhancement set to weak.
LEVEL 2	Edge enhancement set to medium.
LEVEL 3	Edge enhancement set to strong.

## 3.12. **Black Adjust Level**

---

For this product, eight stages to adjust the black level can be set.

### 3.13. Partition Memory & Record

---

The camera body in this system contains 32 GB of high-capacity memory for recording.

This recording memory can be partitioned and assigned to each recording. Memory is partitioned into equal sizes and a maximum of 64 partitions can be set. The partitioned sections are managed by ID numbers.

Each section can be set with completely independent recording conditions, so this feature is convenient when taking consecutive recordings with changed conditions.

#### Important

- Only the following trigger modes are valid when the partition mode is operating in "MODE2".  
"START", "CENTER", "END", "MANUAL"

### 3.14. Input Signals

---

Signals to operate the camera can be input via the terminals on the back of the system's camera. The signals that can be input are listed below.



A signal other than the specified signal must not be input to the connectors.

Use extreme caution as there is a risk of damage to both devices, the input device and the output device.

#### 3.14.1. TRIG SW IN Connector

This trigger is input during the READY or ENDLESS recording state by contact between the BNC connector's shield and a center pin (switch closure). The center pin normally has voltage flowing through it. Use caution to avoiding contact with other pins.

#### 3.14.2. SYNC IN Connector

The system recognizes a TTL signal from other devices as a synchronization signal.

Input voltage is 0V to +12V (H level +4.5V to +12V), positive or negative polarity, pulsewidth is 50 ns or greater.

Operating current is 10 mA recommended, 30 mA maximum.

## 3.15. Using External Triggers

This system can record by receiving trigger signals. The trigger signals that can be used on the system are explained here.

### 3.15.1. Inputting an External Trigger Signal

The only external trigger system that can be used by the system is a contact signal. The circuit diagram is shown below.

◆ TRIG SW IN Circuit Diagram

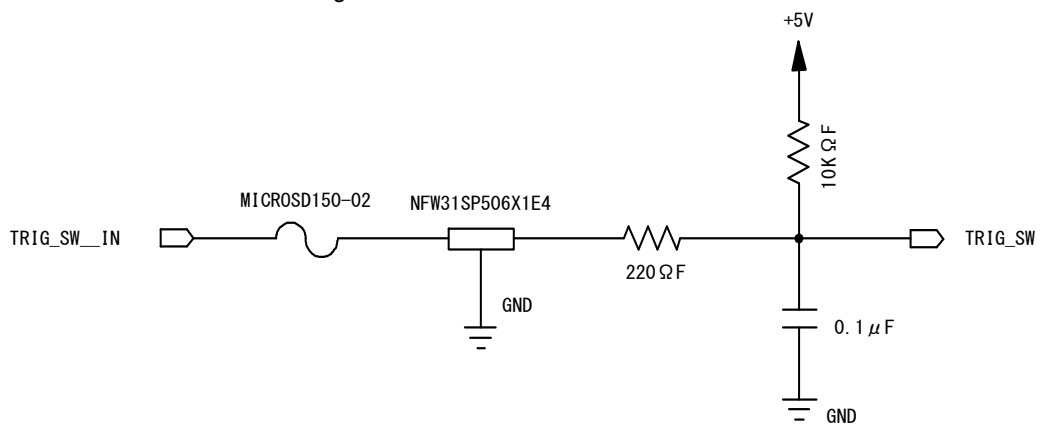

### 3.16. Using External Synchronization Signals

The system provides an external synchronization mode to synchronize to an external signal. By using an external synchronization signal, you can record with the camera synchronized to other external measurement devices or lighting. The procedure and precautions for using the external synchronization signal are explained below.

#### 3.16.1. Inputting an External Synchronization Signal

The system can accept the input of an external synchronization signal. See the chart below for external synchronization input settings.

Menu display	Contents	Signal (input signal conditions)
OFF	Sets external synchronization off, operates independently.	None
ON CAM POS	Synchronizes to a positive polarity signal from an external device (including other Photron products).	TTL level, positive polarity
ON CAM NEG	Synchronizes to a negative polarity signal from an external device (including other Photron products).	TTL level, negative polarity
ON OTHERS POS	Synchronizes to a positive polarity signal from an external device (including other Photron products).	TTL level, positive polarity
ON OTHERS NEG	Synchronizes to a negative polarity signal from an external device (including other Photron products).	TTL level, negative polarity

#### Supplement

- When using "ON CAM POS/NEG", you must match the camera's frame rate to the frequency of the external device in advance, but you can use "3.7 VARIABLE Setting".

---

### 3.16.2. Synchronizing the System with Other External Devices (Frame Rate Synchronized Recording)

---

In addition to the frame rates preset on the system, a function is provided where you can receive a synchronization signal externally, set the frame rate with that frequency, and record.

In this way, for example, the system can be synchronized with a dynamic body that spins at 1,350 revolutions a second to conduct high-speed recording at 1,350 fps. This can open up broad applications that were unavailable until now.

◆ Conceptual Diagram of External Synchronized Recording

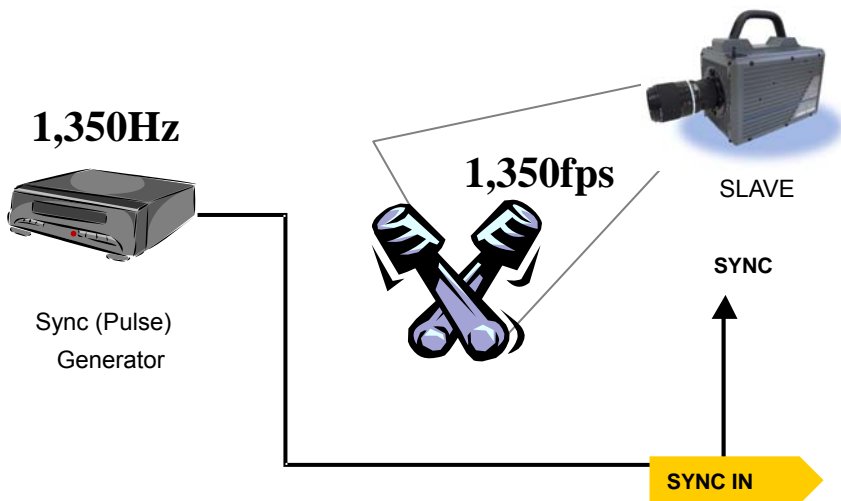

**Important**

- When conducting frame rate synchronization recording on the system, the signal that can be input must meet the following conditions.
  - TTL level, positive polarity or negative polarity
  - 60 Hz (50 Hz when set to PAL) to 86,400 Hz

#### ◆ System settings

##### ■ For PFV (standard)

- ① Verify that the camera mode is in "LIVE" mode (the image displayed is passed through from the camera). If the system is in a mode other than "LIVE" mode, check "Live" on the camera control panel.
- ② Select I/O on the left tree from "Camera Option" on the camera control panel.
- ③ Set "SYNC IN" to "ON CAM POS/NEG" or "ON OTHER POS/NEG".

##### ■ For the Remote controller (optional accessory)

- ① Input the synchronization signal to the system from the device that generates the signal. Connect the synchronizing device's output signal to the system's SYNC IN connector using a BNC cable.
- ② When the synchronization signal is input to the SYNC IN connector, the SYNC IN LED (yellow) on the rear of the system illuminates (\* If the synchronization signal is lost, the LED goes out).
- ③ Press the Remote controller's [MENU] key and the menu list is displayed.
- ④ Select [SYNC IN] from the [SYNC IN/OUT] submenu with the Remote controller's [↑↓←→] keys and press the [ENTER] key.
- ⑤ Select the input signal with the Remote controller's [↑↓←→] keys. Select [POS] (positive polarity) or [NEG] (negative polarity) according to the external synchronization signal's polarity.
- ⑥ When the setting is complete, press the [ENTER] key to finish.
- ⑦ Output the signal from the synchronization device and verify that the system recognizes the output frequency and synchronizes its frame rate. The recognized frame rate will display in the lower left of the video monitor.



### Caution

- The frequency of the synchronization signal cannot be changed during LIVE or recording (outside of spec assurance).  
To change the frequency, repeat the synchronization settings after inputting the changed synchronization frequency.  
The system is re-set.
- If no synchronization signal is input or the input signal is under 60 Hz (50 Hz) when configuration the synchronization settings, or if the synchronization signal is lost, the display shows "NO SYNC INPUT".  
If the synchronization settings are configured when a signal exceeding 86,400 Hz is input, the display shows "OVER SYNC INPUT".  
In either case, you cannot record normally.
- A minute error occurs in the input synchronization signal due to the construction of the internal circuitry of this function.  
An error of  $\pm 18.5$  ns occurs for the input synchronization signal in actual operation.  
Since the frame rate display value on the monitor is in 1 Hz units, the error may be shown larger than the actual operation (an error occurs of about  $\pm 1$  to 5 Hz).

Example: When performing external device synchronization inputting a synchronization signal of 10,000 Hz, the monitor display error is  $10,000 \text{ Hz} \pm 1 \text{ Hz} = 9,999 \text{ fps to } 10,001 \text{ fps}$ .

### 3.16.3. Synchronizing the System with Other Cameras (Mixed Device Synchronized Recording)

---

Using the function (frame rate synchronization recording) in the previous section, "3.16.2 Synchronizing the System with Other External Devices (Frame Rate Synchronized Recording)", mixed-type synchronized recording can be performed with Photron's other high-speed cameras (except for some older products).

◆ Basic procedure

- ① Decide the master camera (the source of the synchronization signal) and the slave camera (the camera that will operate according to the synchronization signal from the master). Basically, by making the master camera the camera with the lowest maximum frame rate that can be set, you can avoid setting a synchronization signal speed the slave camera cannot receive.
- ② Connect the master camera's V-SYNC output connector to the slave camera's V-SYNC input connector with a BNC cable, select the synchronization signal output polarity on the master camera, and then set the slave camera to be operated by that signal.

 Reference

- For camera models that can perform synchronized recording or for detailed instructions on configuring the settings, contact Photron at the contact information in "7.1 Contacting Photron", page74.

---

### 3.17. Signal Delay

---

You can configure the delay time for synchronization signals input on the system. The delay time setting can be configured with PFV or the Remote controller (optional accessory). The content of each setting is listed in the chart below.

Settings	Setting range (value)
SYNC IN DELAY	0-1/frame rate (s) 100 ns units

### 3.18. Using the Programmable Switch (USER SW)

There are four configurable switches on the back of the system. Each switch can be assigned a different function by configuring it with the menu. The content of each setting is listed in the chart below.

◆ For PFV

Setting	Explanation
OFF	No assigned function.
Change frame rate	Raises the frame rate.
Change resolution	Lowers the resolution.
Change shutter speed	Raises the shutter speed.
Change trigger mode	Changes the trigger mode.
Image fit	Adjusts the size of the image displayed on video output to fully fit the display used.
Status display	Displays the status of the camera settings on video output.
Switch LIVE/MEMORY	Switches between LIVE and MEMORY modes.
Record ready	Sets the record ready state.
Record	Starts recording.
Low light	Turns low light mode ON/OFF.
Calibrate	Performs black level calibration. Press this button once and the LEDs on the back of the camera illuminate back and forth from left to right and from right to left to inform you of the ready state. Afterwards, with the sensor shielded, press the button once more to complete calibration.
OSD on/off	Shows/hides the screen text on the video monitor.

---

◆ For the Remote controller (optional accessory)

Setting	Explanation
OFF	No assigned function.
FRAMERATE SEL	Raises the frame rate.
RESOLUTION SEL	Lowers the resolution.
SHUTTER SEL	Raises the shutter speed.
TRIGGER SEL	Changes the trigger mode.
FIT	Same function as the Remote controller's [FIT] key.
STATUS	Same function as the Remote controller's [STATUS] key.
LIVE	Same function as the Remote controller's [LIVE] key.
REC READY	Same function as the Remote controller's [REC READY] key.
REC	Same function as the Remote controller's [REC] key.
LOW LIGHT	Same function as the Remote controller's [LOW LIGHT] key.
CALIBRATE	Same function as the Remote controller's [CALIBRATE] key.
OSD ON/OFF	Shows/hides the screen display on the video monitor.

### 3. Recording

---



## **4. Connecting a PC**

---

### **4.1. Connecting the Gigabit Ethernet Interface to a PC**

## 4.1. Connecting the Gigabit Ethernet Interface to a PC

The system can be controlled from a PC using the Gigabit Ethernet interface. This section explains the required setup when connecting the system to a PC.

### Reference

- For how to operate the Photron FASTCAM Viewer software, refer to the "Photron FASTCAM Viewer User's Manual".

To connect a PC to the system, connect the system to a commercially available 1000BASE-T-compatible interface board with a LAN cable. For the LAN cable, prepare a UTP or STP CAT5e (enhanced category 5) or higher LAN cable (UTP: unshielded, STP: shielded).

The maximum cable length between the PC and the system is, compliant to the 1000BASE-T specification, up to 100 m. One PC can connect to a maximum of 64 Photron Gigabit Ethernet interface equipped cameras using a hub. When connecting multiple devices, connect them through a switching hub that can connect at 1000BASE-T. The maximum length of the cable that connects the system (or PC) to the switching hub is also 100 m.

### ◆ Settings

#### ■ System settings

- IP address

#### ■ PC settings

- IP address
- Packet size
- Time out length
- Communications port

### ! Important

- The system is only 1000BASE-T compatible. When using a PC compatible with only 10BASE-T or 100BASE-TX, the PC must be connected through a 10BASE-T, 100BASE-TX, and 1000BASE-T compatible switching hub.
- The system's factory default IP address is listed below:  
IP ADDRESS > 192.168.0.10  
NETMASK > 255.255.255.0  
GATEWAY ADDRESS > 0.0.0.0  
PORT > 2000 (fixed, not changeable)

### ✎ Supplement

- Photron recommends using an STP cable over long distances or in noisy locations.

### Reference

- For the system's IP address, see "4.1.2 Setting the IP Address", page 51.
- For the PC configuration, refer to the "Photron FASTCAM Viewer User's Manual".

---

### 4.1.1. Connecting the PC and a PC

Connect the LAN cable to the system as shown below.



Insert the LAN cable into the "GIGABIT ETHER" connector.

### 4.1.2. Setting the IP Address

#### **Caution**

- When connecting the system to a PC or when connecting other Gigabit Ethernet interface compatible Photron cameras, set each of those devices to a different IP address. Also, when connecting the system to an existing network, do not use IP addresses that are already in use on the network.

#### **Reference**

- For how to configure the system's IP address, refer to the "Photron FASTCAM Viewer User's Manual" or the "Remote controller User's Manual".

### 4.1.3. Using DHCP (Dynamic Host Configuration Protocol)

The system is compatible with DHCP. In an environment where DHCP is used, the system's IP address can be acquired from the DHCP server.

### 4.1.4. Connecting Multiple Systems and a PC

With PFV, the system's control software, a single PC can connect to and control multiple FASTCAM BC2 HD cameras and Photron's Gigabit Ethernet compatible cameras mixed together.

#### Caution

- When connecting to multiple systems, set the IP address of each one to a unique setting.

### 4.1.5. Gigabit Ethernet Interface Initialization

When you cannot communicate with the camera even when running PFV, the system's control software, you may be able to improve the situation by performing the procedure below.

- ① Of the four programmable switches (USER SW) on the back of the camera body, press and hold USER1 or USER4 for **10 seconds or more (less than 15 seconds)**.
- ② The LEDs on the rear of the camera body will illuminate back and forth from left to right and from right to left and inform you that the initialization of the Gigabit Ethernet interface has completed normally.

#### Caution

- Use caution when pushing a programmable switch (USER SW) for 15 seconds or longer as this will "initialize the camera's IP address".

### 4.1.6. Initializing the Camera's IP Address

If for some reason you change camera's IP address and forget what address you changed it to, you can reset the IP address to the factory default (192.168.0.10) with the procedure listed below.

- ① Of the four programmable switches (USER SW) on the back of the camera body, press and hold USER1 or USER4 for **15 seconds or more**.
- ② The LEDs on the rear of the camera body will illuminate back and forth from left to right and from right to left and inform you that the initialization of the camera's IP address has completed normally.

# 5. Product Specifications

---

**5.1. Specifications**

**5.2. Dimensions**

**5.3. Cleaning the Filter**

## 5.1. Specifications

### 5.1.1. Product Specifications

Image sensor	C-MOS image sensor
Sensor resolution	2,048 x 2,048 pixels
Frame rate	Maximum 1,080 fps when full frame resolution Maximum 86,400 fps at reduced resolution
Lens mount	F mount, C mount (optional accessory), PL mount (optional accessory), B4 mount (optional accessory), EF mount (optional accessory)
Recording color depth	RGB, each 12-bit (Bayer color filter method)
Shutter method	Electronic shutter
Recording method	IC memory
Recording memory capacity	32 GB
Trigger method	START, CENTER, END, MANUAL, RANDOM, RANDOM RESET, RANDOM CENTER, RANDOM MANUAL
Gain control	The camera has a hardware LUT Controllable via the Remote controller or software
Image output customization	Customizable LUT, adjustable brightness
External synchronization input signal	5 Vp-p, negative polarity/positive polarity (switchable)
Trigger input signal	Contact input
External control	Remote controller, RS422 external control I/F Gigabit Ethernet I/F (PC)
Video output signal	HD SDI (SMPTE 292M compliant) <ul style="list-style-type: none"> <li>• NTSC mode 60i / 59.98i / 30p / 29.97p / 24p / 23.98p / 24p(sF) 23.98p(SF)</li> <li>• PAL mode 50i / 25p / 24p / 23.98p / 24p(sF) / 23.98p(sF)</li> </ul> With digital zoom, scroll, fit functions

### 5.1.2. General Specifications

Environment conditions	
Storage temperature	-20°C to 60°C (no condensation)
Storage humidity	85% or less (no condensation)
Guaranteed operating temperature	0°C to 40°C (no condensation)
Guaranteed operating humidity	85% or less (no condensation)
External dimensions	
Camera body	165 (H) x 153 (W) x 250 (D) mm, excluding protrusions
AC power supply unit	49.7 (H) x 82 (W) x 207.6 (D) mm, excluding protrusions
Remote controller	155.4 (H) x 105.4 (W) x 28.1 (D) mm, excluding protrusions
AC power supply	
Power supply voltage	100V to 240V (Up to 125V for type A cable)
Power supply frequency	50 Hz to 60 Hz
Power consumption	100 VA
DC power supply	
Power supply voltage	18V to 36V
Power consumption	100 VA
Weight	
Camera body (without view finder mount)	7.3 kg
Camera body (with view finder mount)	7.9 kg
AC power supply unit	970 g
Remote controller (controller unit itself)	460 g
Remote controller (+7 m cable)	1.15 kg
Remote controller (+0.5 m cable)	620 g



Photron has verified two types of AC cables, type A (standard for Japan, USA, Canada, etc.) and type SE (standard for Germany, France, etc.). However, when those cables cannot properly receive power when plugged in, use the proper AC cable for the region's standards and verify the AC cable works properly.

5.1.3. Optional Accessories

User options
Remote controller
C mount kit
PL mount kit (normal type/shim type)
B4 mount kit
EF mount kit (normal type/remote type)
4 output trigger box
Dedicated carrying case
Spare power supply connector (for creating a custom cable)
Dust-proof LAN connector cover
External battery cable
View finder relay box
View finder mount
Tripod adapter
Monitor pan head set



5. Product Specifications

5.1.4. Frame Rate & Resolution

Image size Frame Rate (fps)	2,048	2,048	2,048	2,048	2,048	2,048	1,920	1,920	1,920	1,920	1,920	1,536	1,536	1,536	1,024
	x 2,048	x 1,536	x 1,472	x 1,280	x 1,080	x 1,024	x 1,536	x 1,280	x 1,080	x 1,024	x 768	x 1,536	x 1,024	x 768	x 1,024
50 (PAL)	○	○	○	○	○	○	○	○	○	○	○	○	○	○	○
60	○	○	○	○	○	○	○	○	○	○	○	○	○	○	○
125	○	○	○	○	○	○	○	○	○	○	○	○	○	○	○
250	○	○	○	○	○	○	○	○	○	○	○	○	○	○	○
500	○	○	○	○	○	○	○	○	○	○	○	○	○	○	○
750	○	○	○	○	○	○	○	○	○	○	○	○	○	○	○
1,000	○	○	○	○	○	○	○	○	○	○	○	○	○	○	○
1,080	○	○	○	○	○	○	○	○	○	○	○	○	○	○	○
1,500			○	○	○	○		○	○	○	○		○	○	○
2,000					○	○			○	○	○		○	○	○
2,500													○	○	○
3,000															○
3,200															○
4,000															
5,000															
6,250															
7,200															
8,000															
9,000															
10,000															
12,500															
16,000															
18,000															
20,000															
30,000															
43,200															
54,000															
86,400															

The circle indicates a possible setting. The green items are the maximum resolution setting at that frame rate. This table is the list of default settings. Even finer settings are possible with the variable setting.

Frame rate (fps)	Image size	1,024	1,024	1,024	768	512	512	512	512	512	256	256	256	256	256	256
		x 768	x 640	x 512	x 512	x 512	x 448	x 416	x 320	x 256	x 256	x 224	x 128	x 96	x 64	x 32
50 (PAL)		o	o	o	o	o	o	o	o	o	o	o	o	o	o	o
60		o	o	o	o	o	o	o	o	o	o	o	o	o	o	o
125		o	o	o	o	o	o	o	o	o	o	o	o	o	o	o
250		o	o	o	o	o	o	o	o	o	o	o	o	o	o	o
500		o	o	o	o	o	o	o	o	o	o	o	o	o	o	o
750		o	o	o	o	o	o	o	o	o	o	o	o	o	o	o
1,000		o	o	o	o	o	o	o	o	o	o	o	o	o	o	o
1,080		o	o	o	o	o	o	o	o	o	o	o	o	o	o	o
1,500		o	o	o	o	o	o	o	o	o	o	o	o	o	o	o
2,000		o	o	o	o	o	o	o	o	o	o	o	o	o	o	o
2,500		o	o	o	o	o	o	o	o	o	o	o	o	o	o	o
3,000		o	o	o	o	o	o	o	o	o	o	o	o	o	o	o
3,200		o	o	o	o	o	o	o	o	o	o	o	o	o	o	o
4,000		o	o	o	o	o	o	o	o	o	o	o	o	o	o	o
5,000			o	o	o	o	o	o	o	o	o	o	o	o	o	o
6,250				o	o	o	o	o	o	o	o	o	o	o	o	o
7,200				o	o	o	o	o	o	o	o	o	o	o	o	o
8,000					o	o	o	o	o	o	o	o	o	o	o	o
9,000						o	o	o	o	o	o	o	o	o	o	o
10,000							o	o	o	o	o	o	o	o	o	o
12,500								o	o	o	o	o	o	o	o	o
16,000									o	o	o	o	o	o	o	o
18,000										o	o	o	o	o	o	o
20,000											o	o	o	o	o	o
30,000												o	o	o	o	o
43,200													o	o	o	o
54,000														o	o	o
86,400																o

The circle indicates a possible setting. The green items are the maximum resolution setting at that frame rate. This table is the list of default settings. Even finer settings are possible with the variable setting.

5.1.5. Recordable Image Count/Resolution

Resolution	Rec. frames
2,048x2,048	5,457
2,048x1,536	7,276
2,048x1,472	7,592
2,048x1,280	8,731
2,048x1,080	10,348
2,048x1,024	10,914
1,920x1,536	7,276
1,920x1,280	8,731
1,920x1,080	10,348
1,920x1,024	10,914
1,920x768	14,552
1,536x1,536	9,701
1,536x1,024	14,552
1,536x768	19,403
1,024x1,024	21,829
1,024x768	29,105
1,024x640	34,926
1,024x512	43,658
768x512	58,211
512x512	87,317
512x448	99,791
512x416	107,467
512x320	139,707
512x256	174,634
256x256	349,269
256x224	399,164
256x128	698,538
256x96	931,384
256x64	1,397,077
256x32	2,794,154

※Recording time = rec. frames x 1/frame rate (fps)

### 5.1.6. Shutter Speed List

Horizontal Resolution	2,048	1,792	1,536	1,280	1,024	768	512	256
Shutter speed	50	50	50	50	50	50	50	50
	60	60	60	60	60	60	60	60
	100	100	100	100	100	100	100	100
	200	200	200	200	200	200	200	200
	300	300	300	300	300	300	300	300
	400	400	400	400	400	400	400	400
	500	500	500	500	500	500	500	500
	600	600	600	600	600	600	600	600
	700	700	700	700	700	700	700	700
	800	800	800	800	800	800	800	800
	900	900	900	900	900	900	900	900
	1,000	1,000	1,000	1,000	1,000	1,000	1,000	1,000
	2,000	2,000	2,000	2,000	2,000	2,000	2,000	2,000
	3,000	3,000	3,000	3,000	3,000	3,000	3,000	3,000
	4,000	4,000	4,000	4,000	4,000	4,000	4,000	4,000
	5,000	5,000	5,000	5,000	5,000	5,000	5,000	5,000
	6,000	6,000	6,000	6,000	6,000	6,000	6,000	6,000
	7,000	7,000	7,000	7,000	7,000	7,000	7,000	7,000
	8,000	8,000	8,000	8,000	8,000	8,000	8,000	8,000
	9,000	9,000	9,000	9,000	9,000	9,000	9,000	9,000
	10,000	10,000	10,000	10,000	10,000	10,000	10,000	10,000
	12,000	12,000	12,000	12,000	12,000	12,000	12,000	12,000
	15,000	15,000	15,000	15,000	15,000	15,000	15,000	15,000
	17,000	17,000	17,000	17,000	17,000	17,000	17,000	17,000
	20,000	20,000	20,000	20,000	20,000	20,000	20,000	20,000
	25,000	25,000	25,000	25,000	25,000	25,000	25,000	25,000
	30,000	30,000	30,000	30,000	30,000	30,000	30,000	30,000
	35,000	35,000	35,000	35,000	35,000	35,000	35,000	35,000
	40,000	40,000	40,000	40,000	40,000	40,000	40,000	40,000
	51,000	50,000	51,000	50,000	50,000	50,000	50,000	50,000
	62,000	60,000	60,000	60,000	61,000	60,000	61,000	60,000
	70,000	71,000	72,000	71,000	72,000	71,000	70,000	70,000
	80,000	80,000	81,000	83,000	82,000	80,000	80,000	81,000
	93,000	92,000	92,000	93,000	91,000	91,000	90,000	89,000
	102,000	99,000	99,000	99,000	102,000	100,000	102,000	99,000
	124,000	119,000	116,000	115,000	116,000	112,000	112,000	111,000
140,000	147,000	126,000	124,000	124,000	126,000	124,000	126,000	
159,000	167,000	156,000	149,000	146,000	146,000	149,000	156,000	
186,000	194,000	202,000	212,000	196,000	208,000	202,000	202,000	
277,000	283,000	289,000	295,000	256,000	266,000	277,000	261,000	
367,000	367,000	367,000	367,000	367,000	367,000	367,000	367,000	

The unit in the chart is 1/x s

 Supplement

- About the configurable shutter

Configurable shutter speeds differ with the horizontal width of the maximum resolution of the frame rate being used. An example is shown below.

Example 1: When using 2,000 fps

The maximum resolution is 2,048x1,080, so the horizontal width is 2,048.

Configurable shutter speeds at this setting are listed in the column titled 2,048.

(See the chart)

Since the frame rate is 2,000 fps, with a maximum exposure of 1/2,000 s, the shutter speeds are listed below.

1/2,000s

1/3,000s

1/4,000s

⋮

1/186,000s

1/277,000s

1/367,000s

Example 2: When using 18,000 fps

The maximum resolution is 256x256, so the horizontal width is 256.

Configurable shutter speeds at this setting are listed in the column titled 256.

Since the frame rate is 18,000 fps, with a maximum exposure of 1/18,000 s, the shutter speeds are listed below.

1/18,000s

1/20,000s

1/25,000s

⋮

1/202,000s

1/261,000s

1/367,000s

---

 Supplement

Example 3: When created with the variable frame rate, resolution function

When a setting of 10,000 fps and a resolution of 256x512 is created and used, the maximum resolution is 256x512.

Configurable shutter speeds at this setting are listed in the column titled 256.

Since the frame rate is 10,000 fps, with a maximum exposure of 1/10,000 s, the shutter speeds are listed below.

1/10,000s

1/12,000s

1/15,000s

⋮

1/202,000s

1/261,000s

1/367,000s

5.1.7. List of Frame Rates Selectable with the VARIABLE Setting

Selectable frame rate (fps)		
50	1,080	9,000
60	1,125	9,600
72	1,200	10,000
96	1,250	10,800
100	1,350	12,000
120	1,440	12,500
125	1,500	13,500
144	1,600	14,400
150	1,800	15,000
180	1,875	16,000
192	2,000	18,000
200	2,160	20,000
216	2,225	21,600
240	2,400	22,500
250	2,500	24,000
288	2,700	25,000
300	2,880	27,000
360	3,000	28,800
384	3,200	30,000
400	3,375	36,000
432	3,600	37,500
450	3,750	40,000
480	4,000	43,200
500	4,320	45,000
540	4,500	48,000
576	4,800	50,000
600	5,000	54,000
720	5,400	60,000
750	6,000	62,500
800	6,250	67,500
864	6,750	72,000
900	7,200	75,000
960	7,500	80,000
1,000	8,000	86,400

## 5.2. Dimensions

### 5.2.1. Camera Body

(mm)

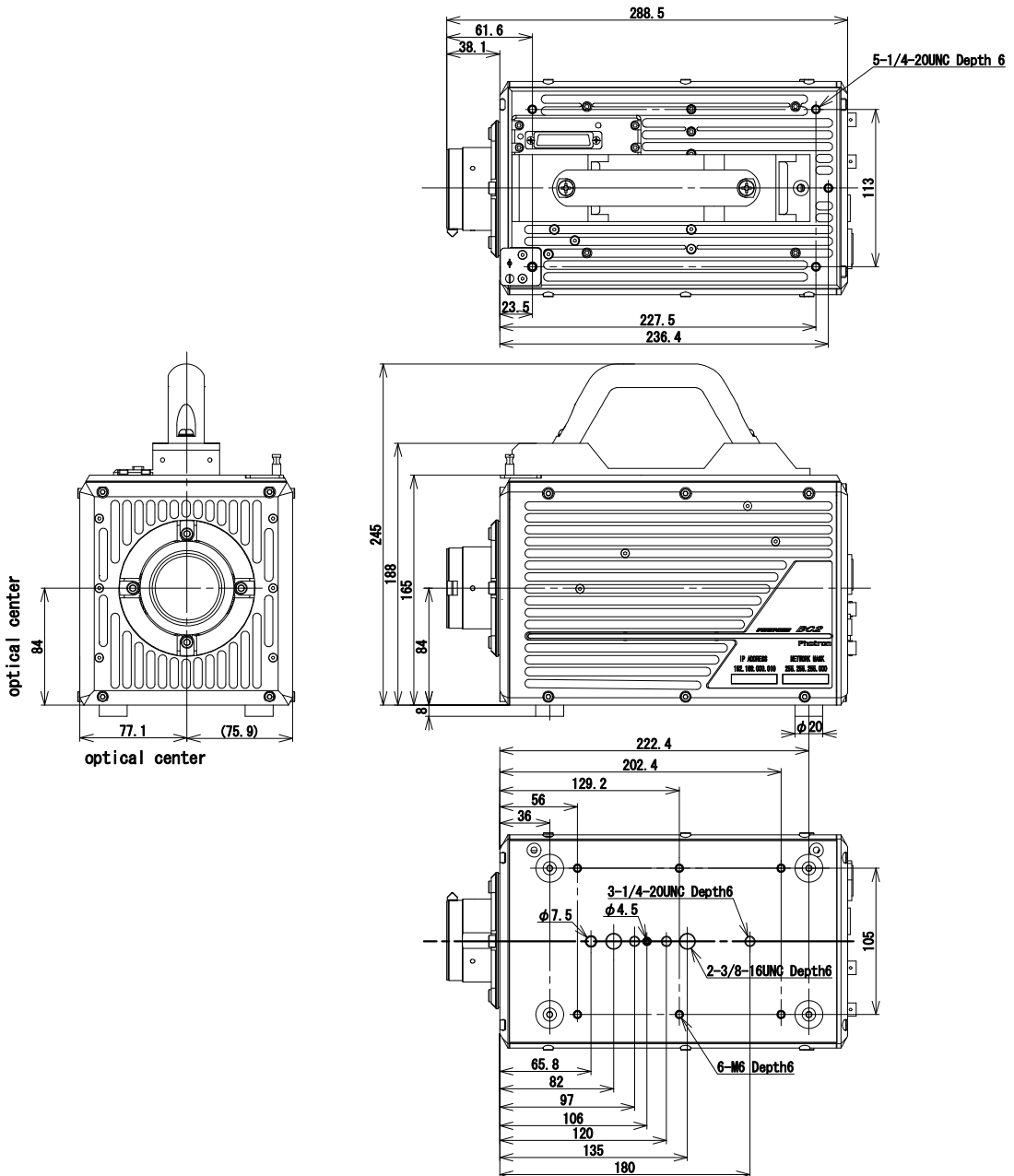



### 5.2.3. Remote controller (Optional Accessory)

(mm)

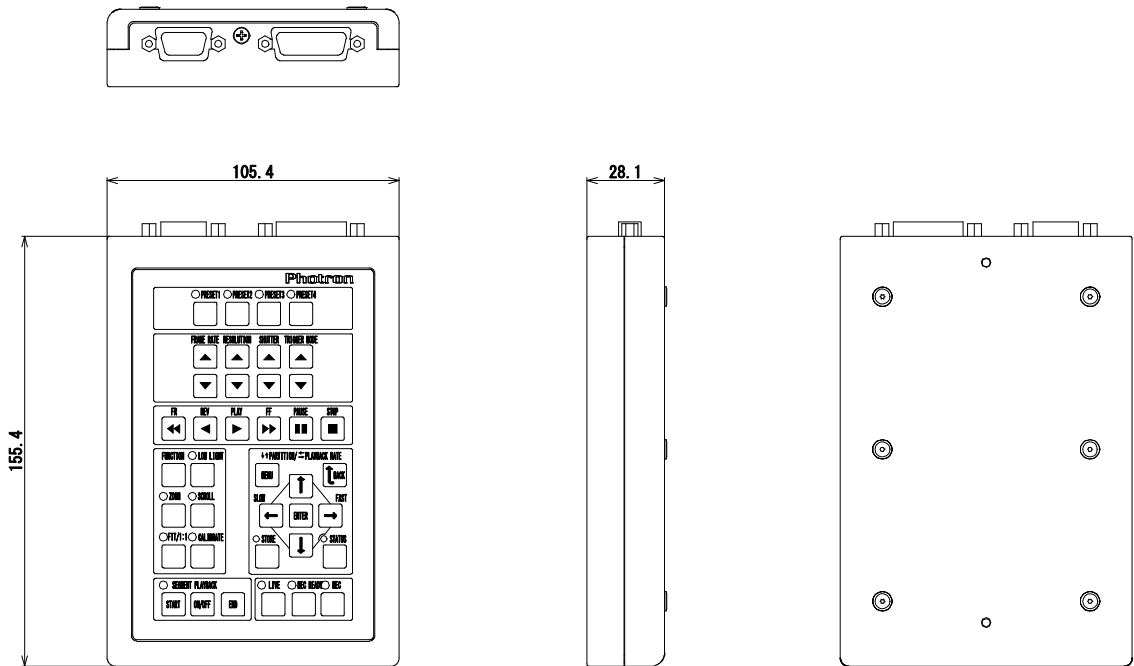

5.2.4. AC Power Supply Adapter

(mm)

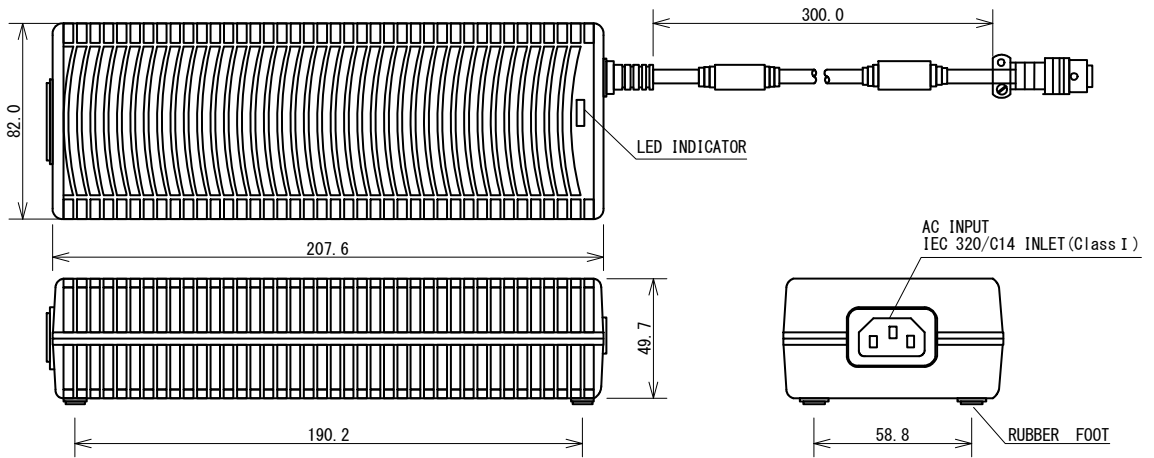

---

## 5.2.5. AC Power Supply Adapter (With AC Cord Anchor Case)

(mm)

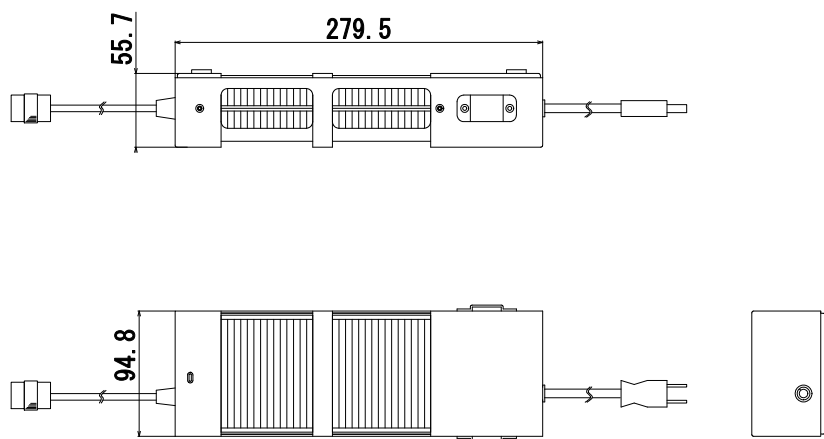

### 5.3. Cleaning the Filter



To prevent the buildup of heat, the system circulates air into the camera body with a fan. In order to lower the risk that dirt and dust in the air will enter the camera, the air vent and exhaust vent are fitted with filters. Regularly clean the filters and the area around the filters in order to keep the system in top condition.

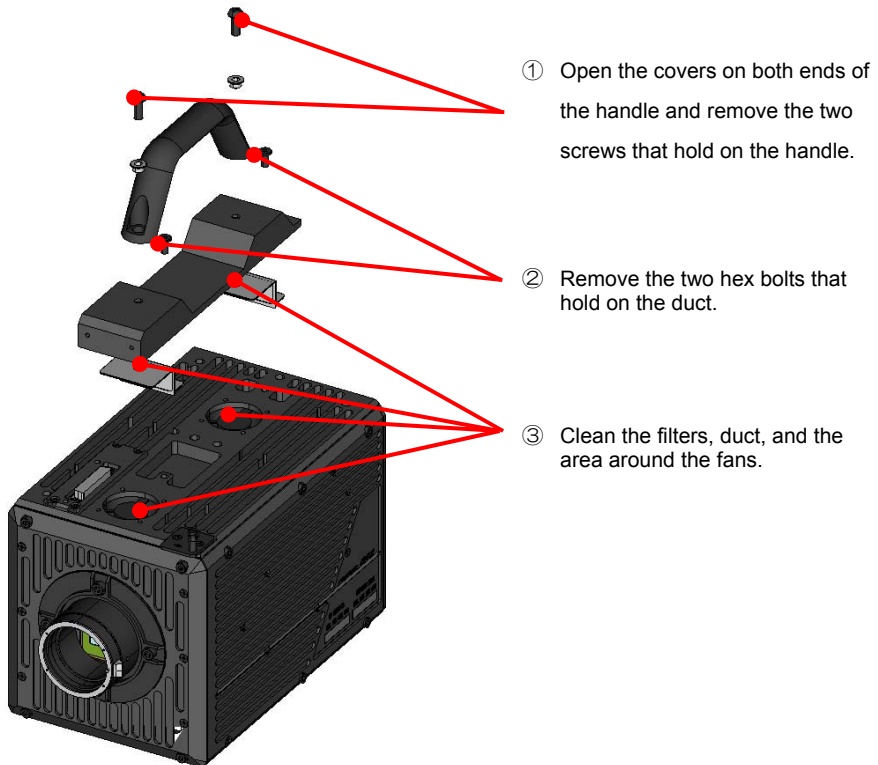

Do not remove any of the screws on the camera body except for those indicated in the diagram above.



The risk of problems occurring with the camera can be lowered by cleaning the filters. However, problems caused by the effects of heat from not cleaning the filters are exempted from warranty service, even if they occur during the system's warranty period.



The filters reduce the risk that dirt and dust will enter the camera body, but there is no guarantee that it will eliminate problems caused by dirt and dust. Take full care with the environment the camera is used in. Problems that occur because dust and dirt that enter the camera are outside the scope of the warranty, even during the warranty period.

---

## **6. Warranty**

---

### **6.1. About the Warranty**

## 6.1. About the Warranty

---

This system has been shipped having undergone rigorous testing. However, in the unlikely event that it malfunctions due to a manufacturing defect, it will be repaired, at no charge, within the warranty period.

### ◆ Warranty Exceptions

The following exceptions will result in fee-based repair, even within the warranty period.

- ① Damage or malfunction as a result of fire, earthquake, water damage, lightning, other natural disasters, pollution, or the effects of abnormal voltage.
- ② Damage or malfunction as a result of dropping or mishandling during shipment or when moving after purchase or misuse.
- ③ Consumable goods (cables)
- ④ When repair, adjustment, or alternation done by an entity other than Photron service has been performed on the system, or damage or malfunction that is determined to be attributed to a fault in the use the product.

For inquires related to malfunction, contact the dealer where the product was purchased, or the nearest Photron office.

### Reference

- For inquires, see "7.1 Contacting Photron", page 74.

# 7. Contacting Photron

---

## 7.1. Contacting Photron

## 7.1. Contacting Photron

For inquiries related to the FASTCAM BC2 HD, contact Photron at the contact information listed below.

When calling, please ensure that you have dialed the correct number.

Additionally, the following items will be verified when inquiring, so please ready them in advance.

Items	Example
Contact information	Company name, customer name, telephone number, etc.
Product name	FASTCAM BC2 HD
Serial number	Check on the nameplate sticker.
Reason of inquiry	System condition or what you know about it

Contact Information	
In Americas and Antipodes	<p><b>PHOTRON USA, INC.</b>                      9520 Padgett Street, Suite 110                      San Diego, CA 92126-4446, USA                      Phone : 800-585-2129 or 858-684-3555                      Fax : 858-684-3558                      E-mail : <a href="mailto:image@photron.com">image@photron.com</a>  <a href="http://www.photron.com">www.photron.com</a></p>
In Europe, Africa and India	<p><b>PHOTRON EUROPE LIMITED</b>                      The Barn, Bottom Road,                      West Wycombe, Buckinghamshire,                      HP14 4BS, U.K.                      Phone : +44(0) 1494 48 1011                      Fax : +44(0) 1494 48 7011                      E-mail : <a href="mailto:image@photron.com">image@photron.com</a>  <a href="http://www.photron.com">www.photron.com</a></p>
In other areas	<p><b>PHOTRON LIMITED</b>                      Fujimi 1-1-8, Chiyoda-Ku                      Tokyo 102-0071, Japan                      Phone : +81 3 3238 2105                      Fax : +81 3 3238 2147                      E-mail : <a href="mailto:digital@photron.co.jp">digital@photron.co.jp</a>  <a href="http://www.photron.co.jp">www.photron.co.jp</a></p>

# *FASTCAM BC2 HD*

Hardware Manual    Revision 1.03E

Publication Date            January, 2012  
Publisher                      PHOTRON LIMITED  
Chiyoda Fujimi Bldg., Fujimi 1-1-8, Chiyoda-ku, Tokyo 102-0071,  
JAPAN